

RESTRICTED

FM 31-30

WAR DEPARTMENT

BASIC FIELD MANUAL



**TACTICS AND TECHNIQUE
OF AIR-BORNE TROOPS**

May 20, 1942

RESTRICTED

FM 31-30

BASIC FIELD MANUAL



**TACTICS AND TECHNIQUE
OF AIR-BORNE TROOPS**



**UNITED STATES
GOVERNMENT PRINTING OFFICE
WASHINGTON : 1942**

WAR DEPARTMENT,
WASHINGTON, May 20, 1942.

FM 31-30, Tactics and Technique of Air-Borne Troops, is published for the information and guidance of all concerned.

[A. G. 062.11 (3-26-42).]

BY ORDER OF THE SECRETARY OF WAR:

G. C. MARSHALL,
Chief of Staff.

OFFICIAL:

J. A. ULIO,
Major General,
The Adjutant General.

DISTRIBUTION:

R and H (5); Bn and L 1-8, 10, 11, 17, 18 (3).
(For explanation of symbols see FM 21-6).

TABLE OF CONTENTS

	Paragraphs	Page
PART ONE. Air landing troops.		
CHAPTER 1. General	1-8	1
CHAPTER 2. Planning and preparation	9-26	8
CHAPTER 3. Tactical operations	27-38	24
PART TWO. Parachute troops.		
CHAPTER 1. Characteristics	39-47	31
CHAPTER 2. Organization and technique of parachute troops.		
SECTION I. General	48	49
II. Parachute rifle squad	49-59	50
III. Parachute 60-mm mortar squad	60-62	53
IV. Parachute rifle platoon	63-64	55
V. Parachute 81-mm mortar platoon	65-66	56
VI. Parachute caliber .30 machine gun platoon	67-68	56
VII. Parachute rifle company	69-73	56
VIII. Parachute battalion	74-76	58
IX. Parachute regiment	77	58
X. Medical detachments	78-80	59
CHAPTER 3. Training.		
SECTION I. General	81	61
II. Unit training	82-84	61
III. Jumpmaster	85-86	63
CHAPTER 4. Supply of parachute units	87-91	68
CHAPTER 5. Tactical employment of parachute units.		
SECTION I. General	92-94	70
II. Sequence of operation	95-106	71
III. Operations to secure landing areas	107	77
IV. Signal communication	108-118	80
CHAPTER 6. Coordination	119-123	85
CHAPTER 7. Advice to instructors.		
SECTION I. General	124	87
II. Technical parachute training	125-128	87
III. Equipment	129-136	90
IV. Packing course	137-141	111
V. Jump training course	142-146	113
VI. Tower training course	147-151	115
VII. Qualification jumping	152-157	118
VIII. Equipment drills and additional training	158-159	125
IX. Specialist schools	160-164	126
INDEX		131

LIST OF REFERENCES

- FM 5-25, Explosives and Demolitions.
- FM 5-30, Engineer Antimechanized Measures.
- FM 7-5, Organization and Tactics of the Rifle Battalion and Components.
- FM 7-10, Rifle Company, Rifle Regiment.
- FM 7-15, Heavy Weapons Company, Rifle Regiment.
- FM 7-20, Rifle Battalion, Rifle Regiment.
- FM 7-25, Headquarters Company, Intelligence and Signal Communication, Rifle Regiment.
- FM 7-30, Service Company and Medical Detachment (Supply and Evacuation) Rifle Regiment.
- FM 7-35, Antitank Company, Rifle Regiment.
- FM 7-40, Rifle Regiment.
- FM 11-5, Missions, Functions, and Signal Communication in General.
- FM 11-10, Organization and Operations in the Infantry Division.
- FM 21-105, Engineer Soldier's Handbook.
- FM 24-5, Signal Communication.
- FM 100-5, Operations.
- FM 101-5, The Staff and Combat Orders.
- FM 101-10, Organization, Technical, and Logistical Data.
- TM 1-440, Parachutes, Aircraft Fabrics, and Clothing.

BASIC FIELD MANUAL

TACTICS AND TECHNIQUE OF AIR-BORNE TROOPS

PART ONE

AIR LANDING TROOPS

CHAPTER 1

GENERAL

■ 1. REFERENCES.—For the general characteristics, organization, and tactics of ground troops, see the appropriate Field Manuals for the arms and services. For a general discussion of troops transported by air and air task forces, see FM 100-5. For logistical data relative to movement by air transport, see FM 101-10.

■ 2. DEFINITIONS.—*a. Air-borne troops.*—Any troops transported by air.

b. Air landing troops.—Troops carried in powered aircraft, or in gliders towed behind aircraft, who disembark after the aircraft or glider reaches the ground.

c. Air task force.—A grouping of air, base, and service units formed to conduct the air missions required by a plan of operations.

d. Task force.—As employed in this manual this term implies a force consisting of an air task force, air landing units composed of appropriate arms or services, and parachute troops. One commander with a staff to assist him is specifically detailed to command all elements of a task force.

e. Bomb safety line.—A line selected on the ground to insure reasonable safety to friendly troops from the effects of bombs dropped by supporting aviation. For their own security friendly ground troops do not pass this line until bombardment aviation lifts its fire.

f. Air alert.—That status in which aircraft are in the air, armed and serviced for the immediate execution of air attack.

■ 3. MISSIONS.—*a.* Suitable missions for air landing troops constituting elements of a task force are discussed in FM 100-5. The mission of the leading echelons of air landing troops is usually to broaden and deepen the combat area established by parachute troops, to assist them in the capture and clearing of landing fields, to relieve parachute troops holding critical areas, and to make landing fields secure from attack so that they may be used by following echelons. During flight and during its initial operations, an air landing force receives its principal support from combat aviation.

b. An air landing force is sometimes used as a mobile reserve for employment in critical areas when means of transportation other than aircraft are unsuitable or unavailable.

c. This manual covers the operations of air landing troops as part of a task force. Air landing troops usually land in an area defended by hostile troops and frequently reinforce parachute troops in the capture, clearing, and security of the landing area.

■ 4. CHARACTERISTICS.—*a. Mobility in air.*—Mobility of air landing troops depends on speed and range of the aircraft in which carried and upon existence and availability of suitable landing areas.

b. Mobility on ground.—Mobility of air landing troops after landing is usually limited to that of foot troops without weapon carriers. However, some carriers and other light vehicles may be transported with the troops. Air landing troops habitually make every effort upon landing to gain greater mobility by requisition or capture of enemy transportation.

c. Vulnerability.—When in flight, an air landing force is very vulnerable to attack by enemy combat aviation and antiaircraft fire. It is particularly vulnerable while landing and for a few minutes thereafter. In flight, protection is provided by pursuit aviation of the air task force. Immediately before and during the landing, aerial bombardment of the defender's position is required to afford protection against antiaircraft fire.

■ 5. ORGANIZATION AND EQUIPMENT.—*a.* An air landing force may consist of—

(1) Specially organized, equipped, and trained units intended exclusively for air landing operations, or

(2) Regularly organized units less heavy vehicles and administrative personnel.

b. With either type of organization, certain changes in personnel and equipment will normally be required to meet the needs of the particular air landing operation under consideration. For example, a battalion whose mission entails jungle operations where heavy weapons are difficult to handle may have a greater proportion of rifles and light automatic weapons and fewer heavy weapons than a regularly organized battalion.

c. Subject to the foregoing exceptions and to lack of organic transportation, other than a limited number of small, light vehicles (par. 4b), air landing troops are provided with their normal equipment. Air transports available will frequently require adjustments of loads of both personnel and equipment to be carried in each type plane.

■ 6. TRAINING.—*a. Commanders and staffs.*—Commanders and staffs of air landing troops are specially trained in the following:

(1) Logistics of enplaning troops, equipment, and supplies.

(2) Planning and execution of tactical operations requiring unusually precise coordination with air forces, parachute troops, and other supporting arms.

(3) Communication with supporting aviation, parachute troops, and task force headquarters.

(4) Administration, supply, and evacuation of units under conditions when normal transportation facilities are lacking.

b. Troops.—Air landing troops are trained in the following:

(1) Enplaning and deplaning, including the loading and securing of equipment.

(2) Technique of operating weapons, particularly those found in the rifle platoon and company. It is essential that all individuals be proficient in use of the rifle or carbine.

(3) Destruction of matériel and installations, such as

enemy weapons of large caliber, bridges, communications, and public utilities.

(4) Operation of captured enemy weapons, transportation, and equipment.

(5) Treatment to be accorded hostile civilian population.

(6) Communication with supporting aircraft by means of panels, pyrotechnics, radio, and prearranged signals, with emphasis on proper designation of targets and methods of identifying themselves to supporting aviation.

(7) Independent operation of small groups which may become separated from their organizations.

(8) Execution of missions to be performed immediately upon landing.

■ 7. SUPPORTING FORCES.—*a. Supporting aviation.*—The missions assigned to the several elements of supporting aircraft are of vital interest to the air landing force. The air elements conduct preliminary bombardment of enemy defenses, transport the air-borne force, protect it in flight and during landing, furnish bombing and machine-gun support during initial operations, and transport ammunition, food, water, medical and other essential supplies, prior to the time other means of transportation become available. Necessity for complete mutual understanding between these two forces is vital.

b. Parachute troops.—Initial operations of an air-borne force are frequently comparable to those of an advance guard in which parachute troops comprise the advance party and air landing troops comprise the support. When parachute troops are not attached to the air landing troops, detailed information of their plans must be secured by the commander of the air landing force, and positive coordination arranged by the task force commander.

■ 8. SUPPORTING COMBAT AVIATION.—*a. General.*—In support of air-borne operations, pursuit aviation operates to gain and maintain effective air superiority over the objective for the period of the operation, and provides security to air-borne troops while in air transit and during landings. Supporting bombardment aviation conducts initial attacks to neutralize enemy ground defenses at or near the objective (in order to

enable parachute and air landing units to effect a landing), and maintains its support until objectives have been gained. Air attacks are directed against ground targets that oppose the operation, and against enemy reserves or reinforcements that threaten it.

b. Limitations.—(1) Ground units should have full appreciation of the powers and limitations of combat aviation in executing missions of close support to their operations. Support cannot always be guaranteed. It may be interrupted by bad weather, enemy interceptions, attacks on airdromes, or strong antiaircraft fire. Aviation supporting ground forces operates at maximum speed at low altitudes and frequently over unfavorable terrain. Consequently it has difficulty in locating and recognizing targets, and in distinguishing between friendly and hostile troops.

(2) Uncertainty of sustained strength in supporting aircraft must be considered. Only the number available for initial operations can be definitely determined. Enemy actions and unfavorable weather conditions will cause losses in aircraft. Neither the numbers which will return to their bases, nor the times at which those that return will be available for future action, can be determined. The number of aircraft immediately available will, after the opening phase, fluctuate throughout the operation. The task force commander should arrange for extra aircraft to replace anticipated losses.

c. Targets.—(1) Targets for supporting aircraft may be either predetermined or transitory. Close-support missions in the immediate vicinity of air landing operations include targets of opportunity. These targets may include troop concentrations or movements, artillery in position or in motion, minor field fortifications such as pill boxes, armored forces and tanks in assembly areas or in motion, motor columns, areas suspected of concealing troops, military bridges, and various field installations.

(2) Small or concealed targets are difficult for bombers to find and hit. In air landing operations, ground elements frequently encounter targets for air attack which they alone are in position to designate to supporting aircraft.

(3) Identification of targets is difficult. It depends upon

many factors such as enemy opposition, visibility, standard of training of individual pilots, and the ability of pilots to locate and recognize targets designated.

d. Methods of control.—(1) The extent to which task force headquarters can determine and assign specific close-support missions during execution of landing operations depends upon distances involved and the communication it is feasible to establish between headquarters and ground and air observers in the combat area. Usually the fast moving situation presented in an air landing operation requires that a portion of the air supporting force be on a status of air alert near the objective, for prompt attack of targets which appear unexpectedly or which may be designated from time to time by landed troops. The vital necessity for close air support during early ground operations usually makes employment of an element of the air task force on a status of air alert essential to success.

(2) In ground operations of air landing troops, the designation of targets for supporting combat aviation and the time of their attack are controlled by the ground force commander. Communication channels must be direct from the ground force to supporting aviation units. This does not preclude attack on targets of opportunity discovered by air elements on an air alert status.

(3) Air support should never be called for if other fire power is available and able to accomplish the desired ends. However, limited means of air landing troops, both in supporting weapons and ammunition, indicate the necessity for insuring that aircraft provide the close-supporting fires normally furnished by infantry supporting weapons and artillery.

e. Training in combined air-ground operations.—(1) Combined air-ground operations require the highest degree of coordination, cooperation, and training. Training includes not only joint air-ground training, but also considerable preparatory training of both ground forces and air forces.

(2) For ground forces the training should include an understanding of the powers and limitations of combat aviation, selection and designation of appropriate targets, identification of aircraft, indicating locations of our troops to

supporting aircraft, methods of control of aviation support, including rapid communication, and map reading.

(3) In training air units, particular attention is paid to accuracy in delivering an attack *at the time* and *on the target* designated by the supported ground force, and to rapid identification of friendly units.

(4) Joint training for close support requires carefully coordinated plans by both ground and air units concerned. Neither unit can complete its training without the coordination and cooperation of the other. The two-way obligation for this type of training will not be minimized. The degree of combined training and the efficiency of communications determine the effectiveness of air support and how close to our own troops the fire power of supporting aviation can be placed.

CHAPTER 2

PLANNING AND PREPARATION

■ 9. GENERAL.—a. The task force commander conducts any preliminary operations necessary to create conditions favorable to execution of the mission assigned to the task force. He requests higher authority to conduct preliminary operations that are beyond means available to the task force. Preliminary operations include preparatory combat operations; establishment of bases; arrangements for movements and concentrations of troops, equipment, and supplies to departure points; detailed reconnaissance of the objective; and preparation of tactical plans. All preparations should be completed well in advance of the date of the operation. Within limits imposed by the necessity for secrecy, subordinate commanders should be given timely information of details of the plan in order that units may have sufficient time to adjust equipment and personnel requirements, prepare plans, and complete special training.

b. The time required by air landing units for preparation and planning depends upon the extent of any reorganization and special training required for the projected operation, and the complexity of arrangements necessary to insure coordinated action with supporting troops, particularly with the air task force.

c. Units of air landing troops, specially organized and trained in air landing operations, are better adapted to employment on air landing missions than are standard units. However, even air landing units require adjustments in organization and equipment for any specific mission.

d. All troops require special training with air task forces and parachute troops prior to employment in air landing operations. Troops landing on a field out of contact with enemy ground forces require no special training other than loading, and unloading personnel and equipment into and from planes.

e. The principles discussed herein are applicable to standard units as well as to air landing units.

■ 10. ORDERS AND INFORMATION FROM HIGHER HEADQUARTERS.—Commanders of air landing units are provided with orders and information from the task force commander giving them full knowledge of the following:

- a. Hostile situation.
- b. General plan of operations.
- c. Forces involved.
- d. Missions of the parachute troops, the air landing force, the air task force, and any ground or naval forces which may be involved in the operation.
- e. Objective of each force.
- f. Time of attack and scheme of maneuver of ground forces.
- g. Combat aviation support missions.
- h. Signal communication arrangements between forces.
- i. Means of identifying friendly agents in enemy territory and assistance to be furnished by them.
- j. Other information necessary to insure coordinated action by all elements of the combined force.

■ 11. INFORMATION OF ENEMY.—Plans of air landing units must be based on accurate and detailed information. Higher headquarters and the task force commander will provide intelligence summaries giving detailed information of enemy activities in the combat area; the location, strength, armament, and character of the hostile force, and its capabilities to interfere with the operation; location of antiaircraft batteries and other defensive installations; composition and type of organized defenses of airdromes, landing fields, and other military and civil installations; characteristics and morale of the civilian population and its effectiveness as part of the defense force; location and types of obstacles used to obstruct possible landing areas; and the location of highly mobile hostile forces.

■ 12. MAPS AND AERIAL PHOTOGRAPHS.—A comprehensive knowledge of the terrain is essential to formulation of detailed tactical plans. Careful study and analysis of aerial

photographs of the area will disclose much of the detail of the hostile defensive positions. Every effort is made to distinguish between actual and dummy positions by the study of a series of photographs taken over a period of time. Maps and aerial photographs of suitable scale are provided. Approximately 50 sets will be required to provide for distribution within an infantry battalion, to include rifle platoons and supporting weapons sections. One hundred sets will be required if distribution is to include squads. Unit commanders study these thoroughly to become familiar with landing and alternate landing sites, towns, roads, streams, prepared defenses, and other terrain features of the combat area. Operation maps and sketches indicating routes, objectives, and other details of initial combat operations are furnished to, or prepared by, subordinate units down to include the platoon or smaller unit having a separate mission.

■ 13. INITIAL OBJECTIVES.—Initial objectives of air landing units will usually include—

a. *Hostile prepared positions.*—Defensive positions in the immediate vicinity of the landing area that are capable of covering the area with small-arms fire will normally be assigned as objectives to the parachute troops. Positions beyond the immediate vicinity of the field will usually be assigned to units of the air landing force. The strength of the attacking unit will be based upon an estimate of the probable strength of the defending force. (This estimate in turn is based upon the size or extent of the defensive position.) Where defensive areas are isolated or separated, as will usually be the case, plans should provide for attack from the flank or rear.

b. *Antiaircraft guns.*—Although the supporting aviation attempts to destroy or neutralize all antiaircraft guns disclosed by aerial photographs or by preliminary operations, each gun position should be assigned as an objective of either the parachute troops or air landing troops arriving in the early echelons. Guns which have been temporarily silenced but not destroyed may return to action with serious effect against transport planes. If these guns can be captured in a serviceable condition, they can be put to good use against

hostile aviation which will make every effort to attack fields being used by air landing troops.

c. Hostile observation.—With capture of hostile positions covering the landing field by small-arms fire, one of the enemy's principal means of defense against an air-borne attack will be long-range fires directed against the landing area. Therefore, initial objectives assigned to air landing troops will include all terrain affording observation over the landing area.

d. Hostile reserves.—Since air-borne troops are particularly vulnerable while landing and immediately thereafter, defending forces will make every effort to launch prompt counterattacks by local reserves. Air landing troops must be on the alert for these attacks. Initial plans for attack by air landing troops should provide for the presence of combat aviation over the landing area with the mission of striking immediately any enemy movement, especially that of hostile mechanized forces. In some situations it may be advisable to assign as initial objectives for air landing units terrain which commands known assembly positions of hostile reserves, in order to immobilize those reserves by fire pending the arrival of sufficient troops to attack and destroy them.

e. Hostile communications.—Objectives of supporting aviation and of parachute troops will include the radio communications of the landing field. Air landing troops are instructed to cut immediately all wire lines they locate, including buried cables which may have been located from aerial photographs. Interruption of hostile messenger routes and control of roads over which reserves may be moved are primary objectives of air landing troops.

f. Hostile transportation.—Lack of organic motor transportation is a great handicap to air-borne troops. Whenever possible, nearby motor parks will be included in the initial objectives for air landing units. Plans should provide for drivers for captured enemy vehicles, for motor mechanics, and for a supply of gasoline and easily removable parts, such as distributor heads and spark plugs, in order to put vehicles into service quickly.

■ 14. METEOROLOGICAL CONDITIONS.—Climate and weather conditions of the combat area affect decisions regarding types of clothing, equipment, and rations, as well as flying and landing operations. Decisions regarding altitude of flight may also affect the type of individual clothing prescribed.

■ 15. ORGANIZATION, EQUIPMENT, AND PERSONNEL.—Modifications in the organization and equipment of air landing units will usually be required for each specific mission. Based on these modifications, the task force commander will issue instructions relative to personnel and equipment to be left behind. Noncombatant personnel, such as clerks and cooks, do not accompany leading echelons. Unit equipment, such as large trucks, kitchen equipment, or other bulky items which cannot be transported or which can be dispensed with during initial phases of the operation, are eliminated. Motor-vehicle operating and maintenance personnel usually accompany leading echelons when there is likelihood of capture of enemy vehicles.

■ 16. SUPPLY.—Because of the limited amount of equipment and supplies that can accompany air landing troops, provision for early and continuous replenishment of ammunition, food, water, medical, and other essential provisions is arranged by the task force commander. Needs of air landing troops are carefully calculated, and arrangements for supplying them are made between supply services, the transport element of the air task force, and air landing troops.

■ 17. SECRECY.—The task force commander prescribes measures to insure that plans and preparations are kept secret. These measures include restricting discussion of plans; prohibiting wearing of distinctive insignia, clothing, and equipment by air-borne troops in the concentration area; removing unit insignia and markings from vehicles; and concealing concentration of troops, equipment, and supplies. Location of landing fields and the day and hour of enplaning are not announced during early phases of preparation. "D"-day and "H"-hour are announced on short notice just prior to the time set for the operation. Instruction which might dis-

close location of the combat area is deferred as long as practicable.

■ 18. TREATMENT OF CIVILIANS IN OCCUPIED TERRITORY.—*a.* The task force commander prescribes measures relative to safeguarding enemy public and private property, and control and treatment of civilians in occupied territory.

b. Fraternization with civilians, unlawful seizure of property, and abuse of individuals, are forbidden. All men are instructed in proper behavior, and distinction is made between measures of military necessity and deliberate misconduct.

c. Operations of troops landing in an area in which the population is generally unfamiliar with the English language may be facilitated by providing each soldier with a "phrase sheet" listing useful phrases and their phonetic equivalent in the foreign language, e. g., "Give me water." The phonetic Spanish equivalent is "Daymay agwa." The following are examples of phrases which may be useful:

"Give me water; food; map; match; gasoline."

"What is the name of this town? River?"

"Which way to the airport? Railroad? Station? Docks?"

"Guide me to . . ."

"Keep off the road."

"Come here."

"Stay in your home."

"Halt."

"Walk in front of me."

"Stay where you are."

"Move along."

"Surrender your weapons; ammunition."

"Hold up your hands."

Personnel speaking the language of the country in which the operations are conducted should be attached to all air landing units.

■ 19. EVACUATION.—Plans do not usually provide for evacuation of wounded from the combat area during the early stages of an air landing operation. Leading echelons of air landing troops include attached medical personnel and limited amounts of medical equipment and essential supplies.

Tactical plans provide for the establishment of unit aid stations immediately after landing, usually in the vicinity of the landing area. Evacuation of wounded by plane or other transportation is initiated by the task force commander as soon as the situation permits.

■ 20. COMMUNICATION.—*a. General.*—The task force commander coordinates communication within the task force by means of signal operation instructions. Special measures are prescribed to insure rapid and positive communication between elements of supporting aviation, parachute troops, and air landing troops. Generally, duplicate means of communication between air elements and ground forces are prescribed to insure continuity of communication.

b. Communication between air landing troops and supporting aviation.—Parachute troops and air landing troops maintain communication with supporting aviation in order to keep the air elements advised of the ground situation, and to be able to call for support, ammunition, food, and other essential supplies where and when needed. Communication between ground and air forces is effected by means of radio, panels, pyrotechnics, and such other means as may be available or improvised. For communication between aircraft and landed troops in close contact with the enemy, codes and signals for prearranged phrases improvised for a particular operation are frequently used. These must be simple, practical, and limited in number, otherwise they will have little combat utility. Whatever the system of communication employed, it is essential that all ground troops, pilots, and air observers receive combined training in its use prior to the operation. All personnel of the task force should keep in mind the possibility of communication codes falling into the hands of the enemy and being used by him to his own advantage, perhaps to direct fire against our own troops. All concerned, particularly combat aviation, must be alert to detect such action. An intimate knowledge of the plans and methods of operation of ground troops by pilots of combat planes minimizes the likelihood of their responding to false calls. Improvised signals and codes outlined hereafter are *not prescribed* but are included merely as illustrative examples.

(1) *Panel communication with combat aircraft.*—Only advance elements of attacking ground forces display marking panels when held up by enemy resistance or when requested to do so by friendly aircraft. Combat aviation, familiar with the general direction of advance of attacking forces, searches the terrain in front of the indicated front-line troops, and without special request attacks any hostile positions discovered. Ground troops may direct the attention of supporting combat planes to targets by displaying panels in prearranged code. Likewise, other prearranged messages may be transmitted by panel code. (See fig. 1.) The code shown is illustrative only.

(2) *Use of pyrotechnics.*—(a) *Plane to ground.*—By means of a prearranged color code, aircraft using the Very pistol may signal ground troops to "mark front line," "mark battalion headquarters," and other definite items.

(b) *Ground to plane.*—Ground troops may signal aircraft by the use of colored ground flares, ground signal projectors, and smoke. For example, the direction to targets might be indicated by establishing the line with two or more smoke pots or flares appropriately separated, or by means of an arrow improvised from panels or other white material.

(3) *Air-ground voice radio.*—(a) In operations involving close support by combat aviation, time is a vital factor, therefore messages may be sent in the clear. Adoption of a coded templet or map-coordinates code for giving coordinates offers a high degree of secrecy with a minimum loss of time. All participating units (ground and air) must use identical equipment for this purpose. A prearranged form for requests increases the degree of secrecy, serves to brief the message, and expedites its transmission. A model for this form follows:

1. Designation of target, including location by a coded templet or map-coordinate code.
2. Time of attack (time bracket).
3. Bomb safety line, if necessary.
4. Special instructions.
5. Time signed and signature.

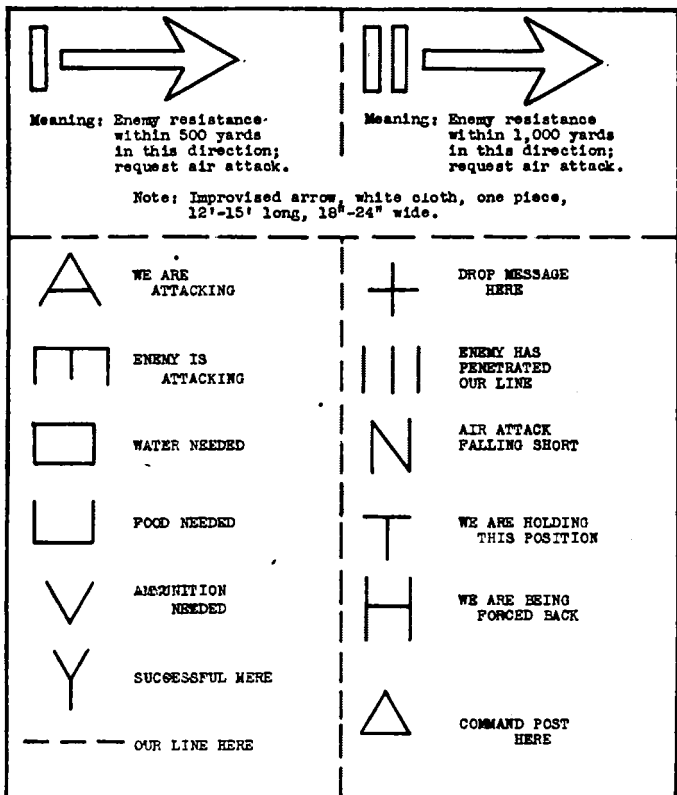

FIGURE 1.—Sample panel code.

(b) *Voice radio air-ground prearranged message code (illustrative).*—To be pronounced phonetically. See FM 24-5.

Encoding and decoding

AA----- Antiaircraft artillery at -----
 AO----- Attack over ----- yards.
 AS----- Attack short ----- yards.
 CA----- Cease air attack here; I am advancing.

CD	Counterattack developing at
DA	Defenses at
FA	Field artillery at
MG	Machine guns at
OO	Objective taken at
RA	Request air attack on enemy
UA	Send rifle ammunition.
UB	Send machine-gun ammunition.
UM	Send mortar ammunition.
UO	Send gasoline.
UR	Send food.
UW	Send water.
WC	Target correct, continue your attack.
WM	Target correct, mission accomplished.
XY	Understood.
YZ	Unsuccessful at

c. Communication between air landing units and other ground elements.—Communication between air landing troops (after deplanement) and parachute troops is effected by radio and messenger. Air landing troops communicate with headquarters of the task force by means of radio, aircraft, and carrier pigeon. When projected operations indicate that a union is to be effected between air-borne troops and ground forces operating elsewhere, arrangements are made for the early establishment of communication between the two forces.

■ 21. **CONFERENCES.**—The task force commander will prescribe conferences between commanders of the air landing troops, the various elements of the air force, parachute troops, and other supporting forces. Preparatory to these conferences the air landing force commander makes tentative plans for execution of the tactical operation involved and preparations therefor, and is prepared to discuss, coordinate, and perfect arrangements with all concerned.

■ 22. **PLANS AND ORDERS.**—*a. General.*—Plans and orders are of two general categories—arrangements for operations prior to take-off from departure airport(s) and those for tactical operations initiated immediately upon arrival at the destination. Since all other activities must be designed to insure

accomplishing the mission of the air landing force, the general tactical plan for initial operations after landing must be made first. Plans and orders of both categories must be detailed and exact. Few details of such an operation lend themselves to a standing operating procedure. Owing to the great strategic mobility of air-borne troops, successive operations may involve employment of the same unit under tropical, desert, and arctic conditions.

b. Disposition of personnel.—Depending upon the tactical operation involved and planes available for the movement, certain personnel will be left behind. (See par. 15.) The task force commander will normally issue instructions specifying by category which personnel are to go and which are to be left behind. Organization commanders will select personnel by name. See FM 101-10 for a sample table showing tabulation of personnel to go and personnel to remain. Arrangements must be made for quartering, messing, administration, and control of the personnel who are to remain.

c. Equipment.—(1) Equipment and supplies carried will vary widely, depending upon the climate of the theater of operations, the nature of expected enemy resistance, estimated duration of the operation, and the number and types of planes available. Detailed tables of individual and organization equipment to be carried will usually be advisable in order to segregate certain individual and organization equipment which may be forwarded subsequently by air transport. For example, instructions might provide that individual rolls containing shelter half, blankets, and other specified articles be tied in squad bundles, tagged, and stacked in a designated locality. Consideration should also be given to the possibility of forwarding a limited amount of kitchen equipment if the operation extends over a greater period of time than was originally contemplated.

(2) Air-borne troops will frequently require special equipment or additional amounts of standard items, such as radio sets of greater range for contact with task force headquarters, additional portable radio sets for issue to subordinate units, additional mortars, panels, pyrotechnics, demolition equipment, and heavy wire cutters. Plans must provide for procurement and issue of this equipment.

(3) Type (or types) and quantity of rations to be carried by the individual and with the units must be determined, and arrangements made for their procurement and issue. Special supplies of chemicals for water purification must be obtained and issued to include platoons.

(4) Decision as to the types and quantities of ammunition to be carried must be made after a careful consideration of all factors. The heavy weight of ammunition for the 81-mm mortar, together with the difficulty of its transportation by hand, must be considered in relation to a greater quantity of 60-mm mortar ammunition and small-arms ammunition for automatic weapons. A high priority will be given to hand grenades, antitank grenades, and ground signals and flares.

(5) If the flight must cross extensive water areas, all troops should be equipped with life preservers and instructed in their use.

■ 23. PLANS FOR MOVEMENT TO DEPARTURE AIRPORT.—The time and method of movement from the training area to the departure airdrome(s) will usually be prescribed by the task force commander. Loading will be facilitated if the movement of personnel and equipment can be made simultaneously by motors. The movement is made in one or more stages depending upon the distance involved. In the interest of secrecy and security, the final staging area should be at least five miles from the airport(s) and well concealed.

■ 24. LOADING PLANS.—*a. Air transport movement table.*—An air transport movement table (see FM 101-10), or data from which the commander of the air landing troops can prepare such a table, will be furnished by the task force commander. In addition to information relative to the number of transport planes to be provided, data as to type or types of ships, and the seating and weight carrying capacity of each type must be furnished.

b. Loading officer.—(1) A staff officer of the air landing force should be detailed as loading officer for each airport to be used. Since the loading plan must be closely integrated with the employment of motor vehicles used in moving men

and equipment to the departure airport(s), the unit transport officer may well be used in this capacity.

(2) The duties of the loading officer include—

(a) Contacting the air operations officer at departure airport.

(b) Obtaining a diagram of the landing field showing the layout of runways and roads.

(c) Securing data relative to the characteristics of planes being furnished, including size of doors, seating and cargo arrangements, and capacities.

(d) Assisting the unit S-3 in preparation of a loading table.

(e) Coordinating with the air operation officer to insure that transport planes are parked for loading in order of take-off.

(f) Meeting and guiding loading groups upon their arrival at the departure airport.

(g) Assignment of loading groups to specific planes.

(h) Providing special loading equipment and personnel to assist in the loading of heavy or bulky equipment.

c. Loading tables.—(1) Loading tables must be flexible, owing to the variety of types of transport planes. With the exception of certain bulky items such as 37-mm antitank guns or ¼-ton trucks, infantry equipment can be loaded in any type plane suitable for the movement of air landing troops. Plane loads are based on unit loading principles and on the cargo weights and passenger capacities of the planes provided. See FM 101-10 for a loading table form.

(2) In order to reduce the time that planes must remain on the ground at their destination, as many planes of the leading wave as possible should be loaded with personnel and their individual equipment only. This will permit all of the load to be removed at one time by the men when they deplane, and enable these planes to depart at once.

■ 25. PLANS FOR TACTICAL OPERATIONS.—*a. Preliminary studies.*—Upon receipt of orders and information from the task force commander (see par. 10) the commander of an air landing unit should make a careful analysis of his mission and the information furnished. From this study the

commander and each of his staff officers should determine whether they have been furnished the necessary data and information. If not, steps are taken immediately to obtain the additional information needed.

b. Tentative tactical plan.—Based upon the initial study and conferences with the commanders of parachute and air task forces, a tentative plan of operation is drawn up. From this general tactical plan, detailed plans and orders for preliminary movements and other administrative matters are worked out.

c. Form and scope of orders.—Orders for air landing operations involve considerable detail. Specific tasks are frequently assigned to smaller units by regimental, battalion, and company commanders. In order to preserve secrecy, all references to time, dates, and places are announced in code only.

d. Issuance of orders.—Initially the order should be issued orally and explained or illustrated by large scale aerial photographs, sketches, and, when possible, on a scale reproduction on a sand table. Following the issuance of the oral order, written copies of the order and annexes are issued. Subordinate commanders in turn prepare and issue their orders. All officers and noncommissioned officers must receive necessary instructions.

e. Scope and contents of orders.—Information of hostile positions and dispositions must be detailed, complete and up-to-date. All concerned must have a complete understanding of the operation of all supporting troops, including missions of the air task force, parachute troops, and air landing troops. Missions and objectives for each unit must be specific. Arrangements for supply and communication must be included in orders of all echelons.

f. Instruction in orders.—Following the issuance of orders, a full discussion of the projected operation is conducted by commanders of all echelons to make sure that each subordinate commander thoroughly understands the part his unit is to play. Company and platoon leaders should conduct the contemplated operation as a sand table exercise. Marked air photos, or sketches made from air photos, are furnished all officers and noncommissioned officers. Commanders must assure themselves not only that subordinates understand what

they are to do, but also that they can point out on the sand table, air photo, and sketch, exactly where they are to go, and can explain the means of orientation which they are to employ.

g. Special preliminary training.—If the unit has had no previous training in movement by air transport, arrangements will be made to secure at least one transport plane of each type to be employed, in order to train the unit in loading and lashing of equipment and in enplaning. If planes cannot be obtained, improvised mock-ups should be constructed. It is particularly important that personnel designated to load large or heavy equipment receive special training in order to obviate the possibility of delay.

h. Rehearsals.—If necessary planes can be made available, a landing field with terrain similar to the scene of the actual operation should be selected, and a rehearsal conducted of the entire operation. If planes are not available, trucks can be used to simulate planes.

i. Training with combat aviation.—Arrangements must be made for joint training of air landing units with the supporting aviation. Subordinate units must receive special training in air-ground communication, in identification of aircraft, and in accurate designation of targets. The commander of the supporting aviation is responsible for thorough training of his command in air-ground cooperation. (See par. 20.)

■ 26. ARRIVAL AT DEPARTURE AIRPORT AND LOADING.—*a.* Plans for the movement should provide that men and material arrive at each departure airport in the order in which they are to depart. To expedite loading and to avoid confusion, men and equipment transported on one truck should load into the same plane.

b. The loading officer (par. 24b), accompanied by the necessary guides, precedes the unit to the airport. Upon arrival he contacts the air operations officer for definite information as to the plan of parking planes for loading and their order of departure. The capacity of each plane is clearly marked.

c. Upon receipt of this information, the loading officer issues necessary instructions to his guides and then stations

them so as to insure orderly movement of the unit to its positions paralleling runways on which the planes are to be parked. Whenever possible, men and equipment are left on trucks until planes have arrived and have been parked for loading.

d. When he is informed that planes are ready, the loading officer moves down the column, assigning unit loads to planes. Trucks then move alongside the planes, and men and equipment are loaded under supervision of the officer or noncommissioned officer in charge of the group. The pilot of each plane, working with the group leader, sees that the plane is properly loaded.

e. When troops and equipment have been loaded, responsibility for the movement passes to the commanding officer of the air unit until planes arrive at their destination, where the air-borne commanders again take charge.

CHAPTER 3

TACTICAL OPERATIONS

■ 27. **GENERAL.**—*a.* If the landing field at the final destination has been secured from hostile small-arms and artillery fire, the subsequent operations of air landing troops will not differ from those of similar units transported by any other method, except for lack of organic transportation and difficulty of supply. This chapter deals with landings of air-borne troops against active hostile opposition.

b. Operations of air landing troops which land shortly after the initial attack of parachute troops are characterized by—

- (1) Speed.
- (2) Initiative on the part of all commanders.
- (3) Boldness, in order to take maximum advantage of initial surprise.
- (4) Lack of supporting fires except by combat aviation.

■ 28. **ACTIVITIES IMMEDIATELY UPON LANDING.**—*a.* Although loading plans will maintain the integrity of tactical units to the greatest extent possible, it will be necessary for leaders of all units above the squad to regain control of their units before proceeding on their missions. This may be accomplished by means of a rendezvous or rallying point selected in advance from maps or aerial photographs. This position should afford cover from small-arms fire. Units having specific missions leave their rendezvous area as soon as the last element reports.

b. Immediately upon landing, troops deplane under orders of the senior officer or noncommissioned officer in the plane. Wherever possible, all supplies and equipment are unloaded by the personnel as they leave the plane. As soon as unloaded, all personnel immediately leave for the initial rallying point or rendezvous of their unit. After the first few flights have landed, men are detailed to meet planes carrying supplies or equipment in order that they may be unloaded promptly and enabled to take off.

c. Upon deplaning, troops immediately assume a deployed formation. Weapons must be instantly available for use. In

moving from the landing area to rendezvous or assembly area, approach march formations are used. In assembly positions and whenever troops halt, they must be immediately disposed for all around defense. Where natural cover is not available they must promptly dig in. Men armed with antitank grenades are included in each echelon. They must be particularly alert for individual tanks or other armored vehicles which may have been dug in and concealed near the field. Antitank guns should be brought in as early as practicable.

d. As each unit is assembled its commander sends a report to the next higher unit. This report will advise the higher commander of any casualties the unit has suffered and the fact that it has proceeded on its scheduled mission, or will state briefly any changes made as a result of the situation existing upon arrival.

e. Men from the first elements of a unit will be posted as guides to insure that elements arriving by later flights are directed to the proper rendezvous.

f. A staff officer, arriving on one of the early planes, should meet commanders of later units to acquaint them with the current situation and advise them of any change of plan required. In addition, this officer should keep his own commander informed as to the condition and status of troops as they arrive.

g. An officer with sufficient assistants should be detailed by the task force commander to control all activities on the landing field. He and some of his assistants should arrive with the first echelon of the air landing troops. His principal mission is to insure rapid unloading of all planes and prompt clearing of the field of men, supplies, and planes in order to keep the landing area clear for succeeding echelons.

h. The commander of the parachute troops who have landed in the area details a liaison officer to contact the air landing troops. This officer will inform commanders of air landing troops of the status of parachute operations.

■ 29. ATTACK TO GAIN INITIAL OBJECTIVES.—The attack of air landing troops to gain initial objectives will be conducted in accordance with detailed plans and orders issued prior to

leaving the departure airport. Commanders of higher units will have little or no opportunity to influence these initial attacks. Regimental commanders and staff officers can best influence the operation during this period by insuring orderly deplanement and assembly of reserve and supporting elements of the regiment.

■ 30. **ATTACK BEYOND INITIAL OBJECTIVES.**—*a. General.*—Attacks beyond the initial objectives should be coordinated. Generally they are initiated only on orders of the task force commander or his representative. However, interruption in communications between the task force commander and the commander on the ground may force the latter to decide upon his own initiative whether or not to continue the attack beyond initial objectives. Before ordering a continuation of the attack on D-day, a commander must consider—

(1) The importance of exploiting to the maximum the initial advantage of surprise.

(2) The importance of the objective selected relative to the success of the operation.

(3) The necessity for occupation of strong defensive positions for the night.

(4) The plan of the task force commander, particularly as to time of landing of additional troops and for continuation of the attack after initial objectives are captured.

b. Objectives.—Objectives for attacks beyond initial objectives may be indicated in the mission assigned in the original order. When the commander on the ground must determine which of these subsequent objectives will best further accomplishment of the assigned mission or plans of the task force, he must consider the following:

(1) *Attack to contact troops landing in adjacent areas.*—In order to split enemy forces and conceal the principal effort of the attacker, as well as to permit an increased rate of arrival of troops in the area, two or more landing areas, separated by several miles, may be employed. In this situation the position of air landing forces will be much more secure once these separated forces have made personal contact. If an enemy force is interposed between these units, a prompt attack should be launched against this force by both landing units, unless previous instructions from the

task force commander prohibit this action. It will rarely be possible for the separate commanders to coordinate their efforts initially, but they do so as soon as communication can be established.

(2) *Separation of elements of the enemy forces.*—Severance of communications between elements of the hostile forces will frequently have decisive effects. Strong consideration should be given to attack of objectives which will place the air landing troops between defending forces, and thus prevent movement of supplies and reinforcements from one force to the other.

(3) *Hostile artillery.*—Initial objectives of air landing troops should deny defending forces observation for artillery fire on the landing fields. However, even unobserved artillery fire falling on a landing field may cause considerable destruction of matériel and planes. Therefore, every effort must be made to destroy all hostile artillery or to drive it beyond range of the landing field. Neutralization of this artillery is a suitable mission for supporting combat aviation.

c. Orders.—Orders for attacks by air landing troops beyond initial objectives are similar to orders for renewal of an attack by any ground forces. They must be clear and concise. They should be issued orally or as written messages in fragmentary form. Rarely will the situation permit subordinate commanders to be assembled to receive orders.

■ 31. NIGHT DISPOSITIONS.—*a.* Employment of air landing troops presupposes air superiority in the area. Movement of any considerable number of troops by the enemy should be extremely difficult if not impossible during daylight. This condition, together with the enemy's familiarity with the terrain, makes night attacks on his part most probable.

b. Plans and necessary reconnaissances for night defensive positions should be completed prior to darkness. These plans, whenever possible, should provide for night dispositions differing from those existing just prior to darkness. Strong outposts must be pushed forward, and patrolling to the front, flanks, and rear must be continuous and aggressive throughout the night.

■ 32. EMPLOYMENT OF RESERVES.—Employment of reserves by air landing troops corresponds in general to that of any

unit of similar size. Frequently, troops whose principal assignment in the operation is that of a reserve element may be employed initially on such missions as protecting the rear or flank of troops actively engaged.

■ 33. **DEFENSE.**—The mission assigned air landing troops is usually offensive in the initial phases of the operation. However, in many operations, such as seizing of a beach, bridgehead, or important communication center, once the initial objective has been captured the mission becomes one of holding the position pending arrival of other military or naval forces. Continuous fronts cannot be held. Dispositions must provide for defense of tactical localities by small units disposed for all around defense with the intervals covered by fire. In general, dispositions will approximate those of an outpost of a defensive position. All routes of communication must be covered. The small number of troops and lack of heavy supporting weapons must be compensated for by strong air support and effective air-ground communication.

■ 34. **COMMUNICATIONS.**—Owing to the normally wide dispersion of air landing forces and the rapidity of action essential for successful operation of these forces, communications are difficult to establish and maintain. Maximum use is made of all standard means of communication, together with such means as may be improvised (see par. 20). The various means of communication are employed as follows:

a. Messengers.—Extensive use is made of foot messengers, and of bicycle and motorcycle messengers using machines transported by air or captured. Special precautions are taken to insure that messengers understand where they are to go and what routes are safe for them to follow.

b. Telephones.—There will usually be little use for wire communication, owing to the weight of material, time necessary to install, abnormally wide fronts, and the rapidity of action of air landing infantry. Sound-powered equipment TE 11 is valuable for use by observation posts and for fire control of infantry mortars. In certain situations temporary use of local communications systems which have been seized may be practicable.

c. Radio.—Small portable voice radios of limited range are particularly valuable for air landing operations. Their use

by units down to include platoons will greatly simplify the control problem for commanders. If the air landing force is smaller than a division, provision must be made to secure additional radio equipment with sufficient range to contact the task force commander and headquarters of the armored or other force which is to relieve it. Radio is also a principal means of contact with supporting combat aviation for battalions and larger units (see par. 20).

d. Panels.—In addition to normal panel procedure for communication with the air, companies and platoons of air landing troops that have special or independent missions employ simple panel codes prescribed by the task force commander to provide for target designation, to report their own locations, and to request needed supplies (see par. 20).

e. Pyrotechnics.—Use of pyrotechnics provides a valuable means of communication with the air. Ground signal projectors, Very pistols, and ground flares may be used.

f. Pigeons.—Pigeons are used by air landing troops as an emergency means of communication.

■ 35. SUPPLY.—*a. General.*—Air landing operations are usually planned for a period of short duration. In general, sufficient supplies are carried initially to cover as much of the operation as possible. However, plans must provide for resupply by air for a considerable period. Owing to lack of transportation for hauling supplies after their delivery at landing fields, consideration must be given to dropping emergency supplies by parachutes.

b. Rations.—Pending development of a special ration for parachute troops and similar units, field ration D and field ration C will normally be issued for air landing operations. The D ration is carried on the person as an individual reserve. Not more than one C ration may also be carried initially by each man.

c. Water.—Except for operations in desert or semiarid regions, the problem of water supply is largely one of purification. Where water must be supplied by air, the five-gallon container is most satisfactory as it facilitates distribution.

d. Ammunition.—It is difficult to compute ammunition requirements of an air landing operation. All other supplies are held to a minimum in order that maximum amounts of ammunition may be carried with the troops. Arrangements

must be made to have ample reserves immediately available at departure airfields for resupply by air. Parachutes and proper containers must be available for dropping emergency replenishment close to the troops. Supporting aviation should be particularly alert for calls for ammunition.

e. Medical supplies.—Owing to the difficulties of evacuation, medical supplies must be ample. Provision must be made for resupply by air.

f. Other supplies and equipment.—Since loss of some planes must be expected, it is essential that a reserve of additional essential articles of equipment be provided at a departure airport, in order that supplies or equipment such as radio sets, machine guns, automatic rifles, and antitank weapons which may be lost or destroyed can be replaced promptly.

■ 36. EVACUATION.—While evacuation of severely wounded by air is possible, loading of these cases would retain planes on the field for some time. Operations of air landing troops usually contemplate that contact will be effected with friendly ground forces within a few days. For these reasons plans usually will not provide for evacuation from the area of the air landing operation. Company aid men of battalion medical sections will accompany their companies. They should be provided with additional first-aid supplies. Wounded men should be evacuated to battalion aid stations and thence to collecting stations near the landing areas. If the air landing force is smaller than a division, regimental medical detachments should be reinforced by additional men and material in order to care for casualties at these collecting stations.

■ 37. PRISONERS AND CAPTURED CIVILIANS.—Arrangements must be made for control and guarding of prisoners and of civilians who are taken into custody. These may be employed in the unloading of supplies and material at the landing fields.

■ 38. CONDUCT OF PERSONNEL.—All officers and noncommissioned officers must take prompt and effective action to insure exemplary conduct on the part of all members of the air landing force. Individuals who mistreat civilians or violate property rights, or whose conduct is in violation of instructions, will be dealt with promptly.

PART TWO
PARACHUTE TROOPS
CHAPTER 1
CHARACTERISTICS

■ 39. REFERENCES.—For tactics and technique of infantry and its operations with other arms, see FM 7-5. For the organization and tactics of the infantry regiment and its component parts, see FM 7-5 to 7-40 inclusive. For a general discussion of troops transported by air and air task forces, see FM 100-5. For logistical data relative to movement by air transport, see FM 101-10. For detailed discussion of task forces, including organization, training, duties of commanders, and the support rendered to air-borne troops by combat aviation, see part one.

■ 40. PARACHUTE TROOPS.—*a. Definition.*—Parachute troops are troops moved by air transport and landed by means of parachutes.

b. Selection.—Members of parachute units are selected from officers and men who volunteer for this service. Eligibility requirements, such as education, length of service, previous training, and physical standards, are prescribed by the War Department. Where choice of volunteer personnel is possible, preference should be given to those of an active, agile type.

■ 41. MISSIONS.—Parachute troops are specially trained, equipped, and organized for the purpose of executing missions in areas not immediately accessible to other friendly troops. Missions assigned to parachute units may include:

a. Seizing and holding terrain suitable for the landing of troop carrying airplanes or gliders.

b. Seizing and holding river and canal crossings, and defiles.

c. Seizing and holding key terrain in the rear of organized beach defenses in conjunction with ground or naval operations.

d. Establishing bridgeheads.

e. Attacking a defended position in rear or flank, or landing

within and attacking the interior of a highly organized perimeter defense.

f. Seizing or destroying vital enemy supply and communication installations.

g. Assisting ground offensives by means of vertical envelopment and subsequent seizure of important terrain and vital enemy establishments.

h. Operating in conjunction with armored forces by consolidating and holding gains made by those units until the arrival of other friendly forces.

i. Seizing and holding landing fields for the operation of friendly aircraft or to deny their use to enemy aircraft.

j. Creating confusion and acting as a diversion to the operations of the main force.

■ 42. OPERATIONS.—*a. General.*—Parachute troops may be considered the spearhead of a vertical envelopment or the advance guard element of air landing troops or other forces. They must seek decisive action immediately upon landing. Success depends largely upon rapid execution of missions assigned to subordinate units. Prompt, decisive, and intelligent leadership is of great importance. Failure of one of the smaller units to accomplish its mission may mean defeat of the entire parachute command involved.

b. Surprise.—There is no field of military endeavor in which surprise is of greater importance than in parachute operations. Surprise in some form is a prerequisite to success. It may be obtained in various ways. For example, the enemy may be surprised by the locality selected for the attack, the density of parachutists per given area, or by the type of weapons with which the parachutists are equipped.

c. Objectives and time limitations.—Parachute troops are assigned specific missions and limited objectives. Initially they can be directly supported only by aviation. Since they are limited to their individual equipment and such equipment and supplies as can be dropped from the air, they cannot hold objectives for long periods. The maximum time they can hold an objective depends largely upon the hostile situation and reaction, and upon the effectiveness of their air support. Consequently, parachute troops are used to

seize objectives pending the prompt arrival of other forces, or to seize objectives which are to be destroyed and abandoned.

d. Type of combat.—Parachute troops are usually required to seize a designated locality by rapid offensive action. This is generally followed by defensive action to hold the locality pending arrival of air landing troops or ground forces.

e. Control.—Because of the unavoidable dispersion incident to mass parachute jumping, and the necessity for speed, initial combat takes the form of quick, aggressive, coordinated action by individuals and small groups. Direction, coordination, and control can be effected only by careful planning. Orders of all parachute units must stress flexibility of operation.

■ 43. PRINCIPLES OF EMPLOYMENT.—The following considerations govern employment of parachute troops:

a. The element of surprise must be present.

b. Parachute troops should not be used for missions that can be performed by other troops.

c. Decision to use parachute troops should be made well in advance of the scheduled date of the operation.

d. A comprehensive knowledge of the terrain involved in the operation is essential.

e. A long range forecast of meteorological conditions should be carefully considered during the planning phase.

f. Because of technical requirements, all parachute troop missions should start from a base which affords the required facilities for packing of parachutes and for making minor repairs. From this base, parachute units may be flown directly to their objective or transported by any available means to a designated air field, to be picked up by their transport airplanes.

g. Terrain objectives to be seized and held should lie in the path of the contemplated advance of friendly forces.

h. Local air superiority must exist.

i. Combat aviation is essential for the protection of parachute troops while in flight and during landing, and for supporting fires before, during, and after landing.

j. Parachute troops should be relieved and withdrawn to their base as soon as practicable after arrival of supporting ground forces.

k. All principles of offensive and defensive action applying to infantry combat are equally applicable to parachute troops.

■ 44. **TERRAIN.**—*a. Conformation.*—The character of the terrain is of prime importance in parachute operations. Clear cultivated fields, free of power lines and similar obstructions, are ideal landing areas. However, parachute units can jump in areas containing scattered woods, with little, if any, resultant loss in combat effectiveness. Large trees, stumps, rocks, or similar obstructions are unquestionably jumping hazards, but they are not insurmountable obstacles. Since cleared areas are likely to be defended more strongly than areas containing hazards to parachute jumping, the number of casualties caused by ground defenders will be greater when the jumps are made in cleared areas. All parachute units should be prepared to jump in difficult terrain.

b. Size of landing areas.—(1) The size of landing areas required depends largely upon the size of the unit jumping, formation of the planes, and efficiency of pilots and jumpmasters. A platoon will usually require a landing area approximately 250 yards wide by 600 yards long. If all men are to be jumped in one passage over the area, 8 to 12 seconds are required for men and equipment to clear the plane. If additional flights successively follow the first platoon at approximately 1,000 yards (or 20 seconds) until an entire battalion has jumped, the time between the first jump and the landing of the last man should not exceed 5 minutes. With this formation a battalion jumps one platoon at a time over the same landing area, and the battalion pattern on the ground should not exceed 800 by 1,200 yards. Experience has shown that the battalion landing area will have a larger pattern than a platoon area because of the large cumulative pilot error occurring when many transports fly in a column formation.

(2) Variations in the flight formation have a direct bearing on the pattern and on the jump time. For example, a forma-

tion may be employed in which each flight of three planes (one platoon of parachute troops) is in V formation, the flights for each company are in staggered line, and each company follows successively in column. The battalion usually jumps a company at a time from this formation. Because of better control and closer formation of the planes, the battalion pattern on the ground should not exceed 500 by 800 yards, and the jump time should not exceed two minutes.

■ 45. EQUIPMENT.—a. See Table of Basic Allowances No. 7.

b. Equipment carried by the individual parachutist is shown in figures 2 and 3. This may be varied, depending upon the situation and the mission of the unit. Items that may be carried, in addition to those shown, include demolition equipment, signal equipment, bayonet, extra ammunition, medical equipment, and the carbine. The amount of equipment carried is limited to that which allows a safe rate of descent. The type of equipment is limited by the fact that any protruding angular objects may foul the suspension lines of the canopy, and the possibility that such objects may cause serious injury to the parachutist, who may have to roll or tumble upon landing.

	<i>Pounds</i>
Helmet, steel, with liner.....	2.7
Parachute assembly, type T-5, complete (main pack on back, reserve pack on chest, static line, and static snap with safety pin).....	33.5
Watch, wrist, 7-jewel.....	0.053
Ration (carried in pants leg).....	.75
Clothing worn:	
Suit, parachutist, jumping, summer (two piece).....	3.7
Boots, parachutist.....	4.4
Gloves, horsehide, unlined.....	0.282
Undershirt, cotton; drawers, cotton; socks, light wool; and identification tags.....	0.625
Articles carried in pockets:	
Center chest pocket:	
Knife, pocket, M-2, with thong.....	0.3
Right chest pocket:	
Maps, message book, and pencil.....	0.344
Left chest pocket:	
Toilet tissue.....	0.125
Compass, watch.....	0.125
Whistle (when needed).....	0.125
Right waist pocket:	
Grenade, hand, fragmentation.....	1.25

Articles carried in pockets—Continued.

	<i>Pounds</i>
Left waist pocket:	
Grenade, hand, fragmentation-----	1.25
Right leg pocket:	
Pistol, automatic, caliber .45, loaded with a clip of 7 rounds-----	2.762
Two extra clips, each loaded with 7 rounds-----	0.962
Handkerchief -----	0.058



FIGURE 2.—Individual paratrooper wearing T-5 troop type parachute and complete jumping equipment.

Articles carried in pockets—Continued.

Left leg pocket:

	<i>Pounds</i>
Rope, parachutist, 20-foot length.....	1.0
Packet, first-aid.....	0.234

NOTE.—If the flight is to cross extensive water areas, the troops should be equipped with life preservers and be instructed in their use.



FIGURE 3.—Side view of individual parachutist, showing main canopy, pack on back, and reserve parachute on chest.

c. For a detailed description of parachutes see TM 1-440. Figure 4 illustrates the performance that can be expected of the 28-foot parachute carrying a man with weights of equipment as indicated. Fourteen to twenty feet per second is considered a reasonably safe rate of descent. The horizontal speed of the soldier at the moment of impact with the ground will be greatly increased by wind.

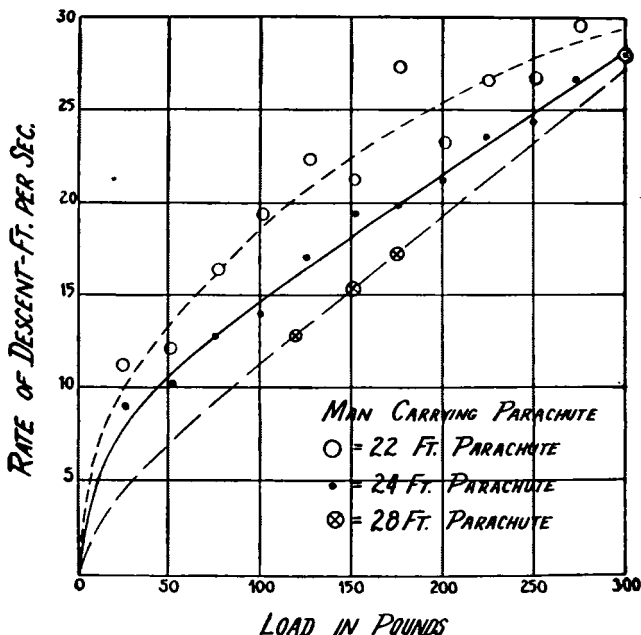

FIGURE 4—Graph showing performance of various sizes of canopies.

■ 46. DELIVERY UNITS.—*a. Definition.*—A delivery unit is a parachute device used for transporting equipment or supplies from an airplane in flight to the ground. It consists of three main parts: the container or harness, the canopy, and the pack assembly.

b. Types.—There are three general types of delivery units, classified according to loads carried:

(1) *Unit type*.—Those designed to carry squad or unit loads of arms and equipment for initial entry into combat.

(2) *General types*.—Those designed to carry food, water, gas masks, medical supplies, certain types of ammunition, and other miscellaneous equipment or supplies.

(3) *Special types*.—Those designed to carry one particular piece of equipment or item of supply, such as boxed ammunition, carts, motorcycles, or crates containing pigeons.

c. Unit type, A-5.—(1) The delivery unit, type A-5, consists of a roll type container, a 24-foot circular cotton canopy, and a conventional "pull off" pack assembly. (See fig. 5.)

(2) The container consists of three parts: 1 felt-padded center section of 22 oz. duck, 56 inches by 180 inches, in which arms and equipment are placed and rolled into a bundle 44 inches long and 18 inches in diameter; and 2 end caps, which fit over the ends of the rolled center section and fasten together by 2 male and female harness fasteners on opposite sides of the roll. The end caps are equipped with 2 V-rings for attaching the risers of the canopy, and 2 V-rings for suspending the unit on bomb racks.

(3) The canopy has 2 risers, connected by a bridle just below the suspension lines, by means of which the container is suspended during descent. These are attached to the suspension lines at one end, and by means of snap fasteners to the V-rings on the container at the other.

(4) The pack assembly consists of a circular pack tray and pack cover into which the canopy is packed in the conventional manner. The pack is attached to one end of the container by tie strings and is opened by means of a 15-foot static line.

d. General types.—(1) *Type A-4*.—(a) The delivery unit, type A-4, consists of a box type container, a 24-foot circular cotton canopy, and a conventional "pull off" pack assembly. (See fig. 6.)

(b) The container is a rectangular bag of duck, 30 by 24 by 12 inches, reinforced on the bottom by plywood, and on top by a metal frame which includes rings for suspension on bomb racks. It has a suitable suspension harness of webbing. Inside the bag may be placed 2 cardboard or light wooden

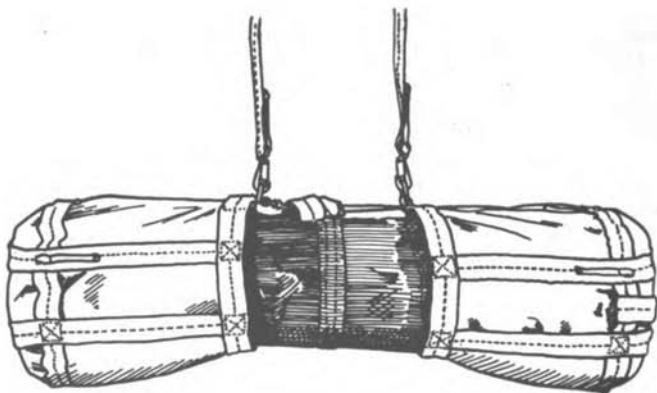

FIGURE 5.—Type A-5 aerial delivery unit.

boxes, each 12 by 12 by 30 inches. However, supplies may be packed in the bag without the use of boxes.

(c) The canopy and pack are of the types used with the delivery unit, type A-5.

(2) *Type A-6.*—(a) The delivery unit, type A-6, consists of a box type container, a 24-foot circular cotton canopy, and a conventional "pull off" pack assembly. (See fig. 7.)

(b) The container consists of two parts: a rectangular duck bag with a suitable suspension harness of webbing; and an inner, replaceable, commercial corrugated fiber box, 12 by 12 by 30 inches.

(c) The canopy and pack are of the types used with the delivery unit, type A-5.

e. Special type A-7.—(1) The delivery unit, type A-7, consists of a harness sling, a 24-foot circular cotton canopy and a conventional "pull off" pack assembly. (See fig. 8.)

(2) The harness is constructed of cotton webbing to fit boxed small-arms ammunition and 37-mm ammunition. It has 2 V-rings for attaching the risers of the canopy.

(3) The canopy and pack are of the types used with the delivery unit, type A-5.

f. Loadings of unit type.—Loads for the delivery unit, type A-5, are limited to 200 pounds, including the weight of the containers.



FIGURE 6.—Type A-4 aerial delivery unit.

g. Loadings of general types.—(1) Loads for delivery units, types A-4 and A-6, are limited to 200 pounds, including the weight of the containers.

(2) Care must be taken that there are no sharp edges or protruding surfaces upon which the total shock of landing might fall. Brittle or breakable items must be well protected by padding.

h. Loadings of the special types.—Since special type delivery units are developed for particular items of equipment, each is constructed to accommodate the load desired. In general, the size of canopy depends upon the weight of the items to be dropped. The following precautions should be observed:

(1) *Delivery unit, type A-7.*—Remove wing bolts and open tin liner prior to placing in harness.

(2) *Packing 81-mm mortar.*—The 81-mm mortar can be readily packed in the standard type A-5 delivery unit in the following manner:

(a) Adjust the bipod so that a block of wood, 5 by 5 inches, can be placed between the ends of the legs, and place the elevation and traverse vernier to face the center of the roll when packed.

(b) Wrap the sight in $\frac{3}{4}$ -inch felt padding, place between the legs of the bipod, and wrap the chain around all three to prevent shifting. (See figs. 9 and 10.)

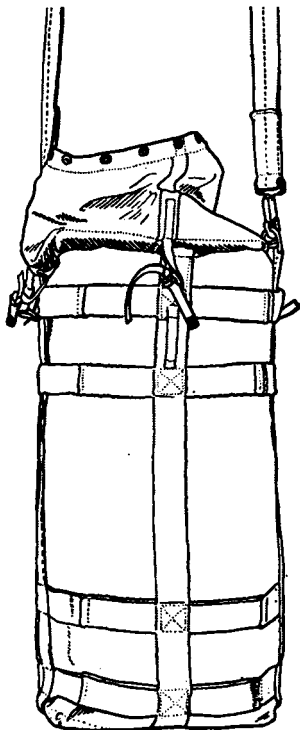

FIGURE 7.—Type A-6 aerial delivery unit.



FIGURE 8.—Type A-7 ammunition delivery unit with canopy in pack preparatory to dropping.

(c) Stow the base plate outside the roll with its ends entering the end caps of the container. Two additional pieces of "1,200 lbs." webbing are necessary to hold the base plate in place and prevent shifting. The arrangement of the additional webbing is shown in figure 9. The base plate is stowed opposite the points of suspension so that it will land at the bottom of the roll.

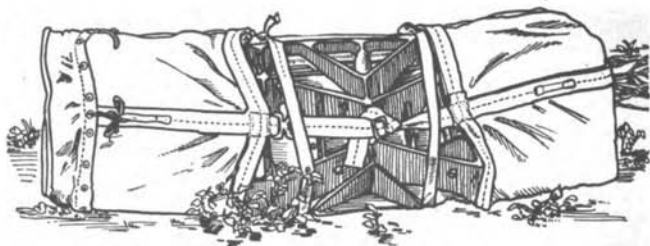

FIGURE 9.—Type A-5 aerial delivery container, showing base plate rig for dropping 81-mm mortar complete. The barrel and bipod are inside the roll.

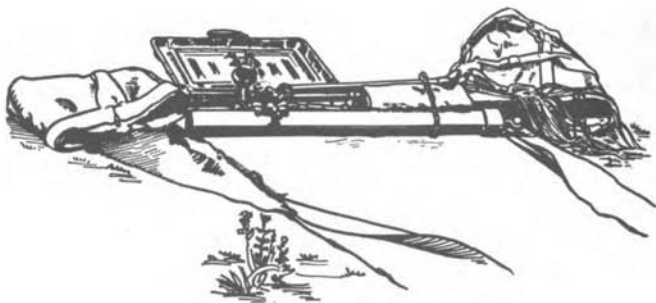

FIGURE 10.—81-mm mortar displayed after being dropped in an A-5 aerial delivery unit.

(3) *Other, special loadings.*—For dropping guns, small vehicles, and other special loads, there are available 48-foot and 36-foot heavy duty canopies. These large canopies, as well as clusters of smaller standard canopies, may be used for heavy loads. See figures 11 and 12 for the performance of these canopies in carrying various loads.

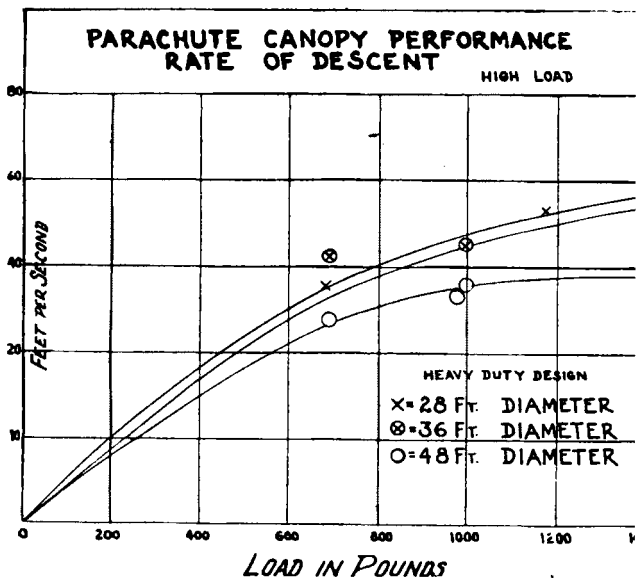

FIGURE 11.

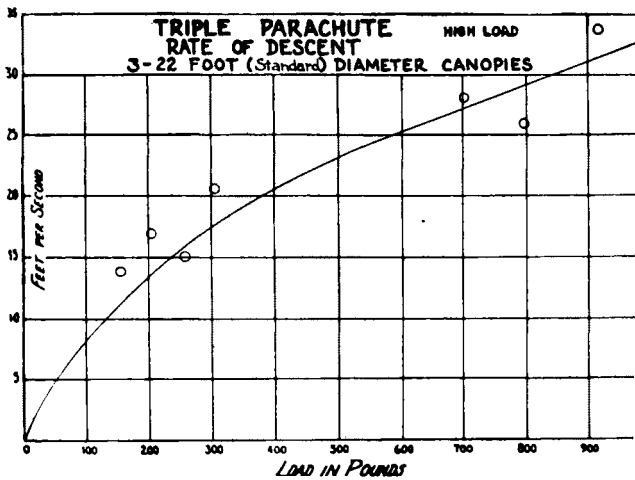

FIGURE 12.

i. Markings.—(1) *General.*—A scheme of distinctive marking of delivery units is advisable to enable personnel to determine quickly the contents of the loads and their destinations. This is most important with unit type delivery units. Different loads may be marked for quick identification by a number of methods. The most satisfactory method is to use colored canopies and, by prearrangement, have each color indicate the nature of the contents. Further to facilitate identification of loads, there may be employed a system of large numbers, either stenciled or sewed on the canopies. If sufficient additional arms and equipment are available, extra delivery units may be dropped and individual soldiers authorized to obtain weapons from the nearest correct *type* bundle as indicated by the color of its canopy. To further deception in subsequent operations, parachute unit commanders should vary the types of loads dropped with various colors. White as well as colored canopies should be employed for delivery units. For a particular operation, only the members of the parachute unit concerned should be informed of the method of identifying delivery units.

(2) *Methods.*—There are three general methods upon which to base an identification scheme:

(a) *Shape of load.*—Any item or load which has a peculiar shape, capable of being readily recognized at some distance, generally needs no other marking. This is the simplest method.

(b) *Contents of load.*—A second method is based upon the contents of the load, for example, making the canopies for all mortar delivery units one color and rifle units another. This necessitates standard loading, and in this case no effort is made to drop particular delivery units to a particular organization.

(c) *Destination of load.*—A third method is based upon destination of the load. The delivery unit is marked to show the parachute unit to which it belongs. In this method the contents need not be standard.

j. Improvised loads.—(1) Occasionally it is necessary to improvise loads of equipment for a special mission. If further need of like loads is foreseen, these improvised loads should be developed into special units.

(2) The following general rules should be observed in the rigging of improvised loads:

(a) Accomplish rigging only under the supervision of qualified parachute maintenance personnel.

(b) Select the proper size canopy or cluster for the load. The load limits governing standard delivery units should not be exceeded when these same canopies are used with improvised loads.

(c) Construct the harness for the load so as to distribute the opening shock load equally throughout the harness, being careful that the tensile strength of the material used in any one part is not exceeded. Provide an ample factor of safety between the shock load expected and the tensile strength of the material used in the harness, remembering that the entire rigging will be no stronger than its weakest part. See TM 1-440 for specifications of materials.

■ 47. TRANSPORTATION.—*a. Transport aircraft.*—A transport airplane for parachute troops should possess the following characteristics:

(1) In addition to the airplane crew it should be able to carry with reasonable comfort thirteen parachutists and at least three loaded delivery units weighing 200 pounds each.

(2) High speed, in order to provide maximum safety from antiaircraft fire and to permit completion of the mission before enemy pursuit planes can attack in force.

(3) Be capable of a speed as low as 100 miles per hour to permit troops to take to parachutes at the jump point without the shock caused by sudden parachute openings produced by higher speeds, to produce as short a landing pattern on the ground as possible, and to prevent rupture of equipment parachute canopies and resulting damage to matériel.

(4) Necessary instruments to locate the parachute landing area.

(5) Have at least one door or other opening of suitable size and location to enable the jumper to make a safe exit and clear all plane surfaces. Doors should be constructed so that they can be opened and closed from the inside during flight.

(6) Be equipped with mechanical aerial-delivery unit ejectors capable of positive and quick action.

(7) Have installed a static line anchor cable long enough, preferably, to have all static line snaps fastened to it simultaneously.

b. Bombardment aircraft.—Although they do not meet all the requirements outlined above, bombardment aircraft may be used to transport parachute troops. Arrangements must be made to anchor the static lines of the present fixed-station type parachutes, otherwise free-fall type parachutes must be used. Most types of bombardment aircraft are not capable of carrying as many parachutists as a transport airplane.

CHAPTER 2

ORGANIZATION AND TECHNIQUE OF PARACHUTE
UNITS

	Paragraphs
SECTION I. General	48
II. Parachute rifle squad.....	49-59
III. Parachute 60-mm mortar squad.....	60-62
IV. Parachute rifle platoon.....	63-64
V. Parachute 81-mm mortar platoon.....	65-66
VI. Parachute caliber .30 machine-gun platoon.....	67-68
VII. Parachute rifle company.....	69-73
VIII. Parachute battalion.....	74-76
IX. Parachute regiment.....	77
X. Medical detachments.....	78-80

SECTION I

GENERAL

■ 48. GENERAL.—The vital need for flexibility in parachute units demands that the smaller components be as nearly self-sustaining as possible. This, in turn, requires that each individual in the squad be capable of performing the duties of any other member of the squad. In addition, every member of a parachute platoon should be able to fire effectively all types of weapons in the platoon. Since administrative personnel of parachute troops do not accompany the combat units, all personnel having duties incident to mess, administration, and supply are concentrated in battalion or regimental headquarters. In general, the duties of commanders, leaders of small units, and staff officers correspond to those of analogous personnel in the rifle regiment. In addition, they have certain other duties peculiar to parachute troops, as indicated hereafter. For detailed organization see Tables of Organization.

SECTION II

PARACHUTE RIFLE SQUAD

■ 49. COMPOSITION.—The parachute rifle squad consists of two noncommissioned officers (a sergeant and a corporal) and ten privates. The sergeant commands the squad and may act as jumpmaster; the corporal assists the squad leader.

■ 50. ARMAMENT AND EQUIPMENT.—Armament of a rifle squad includes ten rifles, a submachine gun, and a light machine gun. These weapons, together with equipment as prescribed by Table of Basic Allowances No. 7, are dropped in delivery units.

■ 51. DUTIES OF THE SQUAD LEADER.—The squad leader is responsible for the conduct and equipment of his squad and for execution of the platoon leader's orders. He supervises and inspects the packing of all parachutes. He checks and inspects the packing of his squad equipment in supply containers and inspects the squad immediately prior to enplaning. When so instructed by his platoon commander he divides his squad into half squads or other subdivisions in such manner as to take advantage of the special qualifications, training, and other characteristics of the individuals. When separated from his platoon leader during combat, he acts on his own initiative and assumes full responsibility for the squad.

■ 52. MISSIONS.—*a.* When operating as part of a larger unit, the missions of the parachute squad are substantially the same as those for any other infantry squad. However, the parachute squad usually is given much greater freedom of action than the infantry squad and may act independently.

b. Exceptionally, the parachute squad, the half squad, or even individuals may be assigned independent missions which involve operations deep in the enemy's rear areas. Usually no support is planned for such operations; however, possible routes and methods of escape are carefully planned in advance. The tasks assigned ordinarily involve demolitions, such as destruction of a factory, a key railroad bridge, a vital dock facility, a critical communication center, or other important enemy installations. Such mission can be

accomplished only by secrecy, surprise, and utmost speed of execution.

■ 53. **ASSEMBLY POINTS.**—Immediately upon landing, the individual soldier is trained to proceed to the designated assembly point of his squad or subdivision. This procedure should be habitual. Exceptions will occur only when individuals are assigned initial missions away from the squad.

■ 54. **SUPPLY OF EQUIPMENT AND AMMUNITION.**—*a. Initial.*—Except for hand grenades and a small amount of ammunition for pistols or other light weapons, carried by descending parachutists, the initial ammunition supply for the squad is dropped in the delivery units that carry its other weapons. At least one day's supply for each weapon is dropped simultaneously with the squad. Delivery units for each group must be landed close to it. Delivery units are clearly marked to indicate their contents and the group to which they belong. Delivery unit parachutes may be marked by the use of colored canopies. However, the colors of canopies should be varied in different operations so that a canopy of a certain color will not always indicate the same piece of equipment. For deception, colored canopies may be used occasionally for personnel. Equipment containers are marked by colored coverings, smoke signals, colored streamers, or other readily recognized devices. (See par. 46i.)

b. Packing and loading.—The squad packs prescribed arms, equipment, and supplies in delivery units under supervision of the platoon leader. Prior to enplaning, these delivery units are placed in equipment racks or loaded in the plane under supervision of the jumpmaster.

c. Subsequent supply.—When the squad is acting alone, the squad leader makes requests upon supporting aviation for his needs by means of prearranged signals.

■ 55. **RATION AND WATER SUPPLY.**—Appropriate field rations and water for at least one day are dropped in delivery units containing the weapons for each subgroup of the squad. Class D rations may be carried by the individual jumper. When two or more days' rations are desired, and space in the unit delivery units is not sufficient, these extra rations may be dropped in a separate delivery unit along with those con-

taining weapons, and picked up by troops when the situation permits.

■ 56. SQUAD PARACHUTE TECHNIQUE.—*a. Forming the squad for inspection before enplaning.*—For inspection of parachutes prior to enplaning for jumping, the squad is formed in a single rank at normal intervals, with the squad leader on the right flank and the assistant squad leader on the left flank.

b. Inspection before enplaning.—At the command INSPECT PACK, given by the squad leader, each man opens the inspection flap cover of his reserve rip-cord assembly and personally checks to see that the pins of his rip cord are seated firmly and securely in the rip-cord pin cone of the assembly. He inspects the pack opening elastics of his reserve parachute for elasticity and secure fastening. The officer or noncommissioned officer designated as jumpmaster then inspects the parachute of each man as outlined in paragraph 86b and—

(1) Checks adjustment of the harness and fastening of the harness snaps.

(2) Checks tacking of the risers of the training reserve and main parachutes, and snap fasteners that connect the training reserve to the harness assembly.

(3) Checks to insure that the static line is secured to the proper adapter.

(4) Checks to insure that the static line is neatly stowed and bound with the elastic.

(5) Checks to insure that lacing of the pack cover and the pack frame are not damaged or loosened in any manner.

(6) Checks sewing of the static line to the pack cover to determine that it has not been weakened.

(7) Examines static line snap fastener.

■ 57. ENPLANING OF SQUAD.—After inspection, the squad is marched to the plane and enplaned. Members of the squad enter the plane in reverse order to that in which they will jump. After enplaning, the squad leader checks his squad and, unless he is the jumpmaster, reports, "All present and ready," to the jumpmaster.

■ 58. PROCEDURE FOR SQUAD MASS JUMP.—*a.* Upon nearing the jump area the jumpmaster directs the pilot upon the

course desired. Ten minutes before time to jump, the jumpers should be given notice. At this time the command **STAND UP** is given. All jumpers rise and check their arms and equipment. Five minutes before time to jump they are given the command **HOOK UP**, followed by **CHECK EQUIPMENT**. (See par. 86.) The check of equipment is verified by having the jumpers "sound off." When the jumpmaster is satisfied that the pilot is on the course, he hooks up, gives the command **STAND TO DOOR**, and takes his place in the door at the head of the squad. He commands: **READY**, a fraction of a second before giving the command **GO**, to be certain that the squad will be ready to follow immediately. He jumps, followed by the remainder of the group. The assistant squad leader jumps last.

b. If the plane carrying the squad is provided with equipment racks, the assistant squad leader releases the squad equipment bundles. This may be done either simultaneously or individually, according to previous arrangement. If the plan is to drop bundles individually, the bundle containing the arms and equipment for each group within the squad is released as the last member of the group leaves the plane. The assistant squad leader releases the bundle for the last group immediately before he jumps. If planes have no equipment racks, all bundles for a platoon are carried in an equipment plane. (See par. 99.)

■ 59. **ASSEMBLY AFTER LANDING.**—Upon landing, the squad secures its equipment from its delivery unit or units, and assembles at a previously designated point.

SECTION III

PARACHUTE 60-MM MORTAR SQUAD

■ 60. **COMPOSITION.**—The mortar squad consists of one sergeant, squad leader, and five privates, first class—a gunner, assistant gunner, and three ammunition bearers.

■ 61. **ARMAMENT AND EQUIPMENT.**—The armament of a parachute 60-mm mortar squad consists of one 60-mm mortar, one submachine gun, and three rifles. For details of equipment see Table of Basic Allowances No. 7.

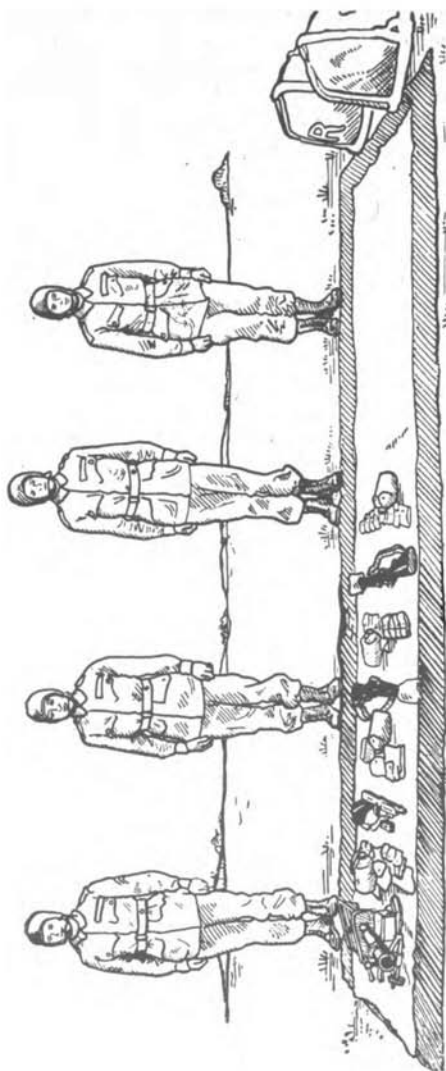

FIGURE 13.—60-mm mortar, submachine gun, and rifles displayed on an A-5 type aerial delivery unit.

■ 62. JUMPING TECHNIQUE.—The squad jumps and assembles in the same manner as prescribed for the rifle squad.

SECTION IV

PARACHUTE RIFLE PLATOON

■ 63. COMPOSITION.—The parachute rifle platoon consists of a command group, two rifle squads, and one mortar squad. The command group consists of platoon leader, second-in-command, platoon sergeant, signal corporal, radio operator, and two messengers.

■ 64. DUTIES OF PERSONNEL.—*a.* The commander of a parachute platoon performs the duties of an infantry rifle platoon commander, and in addition is responsible—

(1) That the condition of all parachute equipment of his platoon is satisfactory.

(2) For thorough inspection of all parachute jumping and training equipment used by his platoon, with particular attention to all details concerning the safety of individuals.

(3) For supervision of the inspection of parachute equipment prescribed in paragraph 86.

(4) For constant observation of all members of his platoon in order to detect any prejudicial physical or mental deficiencies.

(5) For designation of the order in which his squads jump, assembly point(s) after landing, and when appropriate, the rallying point for subsequent assembly.

(6) For efficient air-ground communication, if the platoon is acting alone.

(7) That all of his men are thoroughly acquainted with the platoon mission and with their individual or group missions.

(8) For designation of men to operate any special weapons or equipment involved in the mission, and for supervising their training.

b. The second-in-command assists the platoon leader and performs such duties as he directs.

c. The signal corporal is in charge of all means of signal communications within the platoon.

d. In general, the platoon sergeant and messengers perform the duties prescribed for corresponding personnel in the rifle platoon of a rifle regiment. The radio operator accompanies the platoon leader.

SECTION V

PARACHUTE 81-MM MORTAR PLATOON

■ 65. COMPOSITION.—The parachute 81-mm mortar platoon consists of platoon headquarters and two sections. For details of armament and equipment, see Table of Basic Allowances No. 7.

■ 66. DUTIES.—The commander of a parachute 81-mm mortar platoon performs the duties of an 81-mm mortar platoon commander in a rifle regiment, and in addition is responsible for items listed for the parachute rifle platoon commander. (See par. 64a.)

SECTION VI

PARACHUTE CALIBER .30 MACHINE-GUN PLATOON

■ 67. COMPOSITION.—The parachute caliber .30 machine-gun platoon consists of a headquarters and two sections. For details of armament and equipment, see Table of Basic Allowances No. 7.

■ 68. DUTIES.—The commander of a parachute caliber .30 machine-gun platoon performs the duties of a caliber .30 machine-gun platoon commander in a rifle regiment, and in addition is responsible for items listed for the parachute rifle platoon commander. (See par. 64a.)

SECTION VII

PARACHUTE RIFLE COMPANY

■ 69. COMPOSITION.—The parachute rifle company consists of a command group and three rifle platoons. The command group consists of a company commander, a second-in-command, and a small group of enlisted men to assist the company commander in tactical control of the company, to operate

communication equipment, and to protect the command post. There are no mess, supply, or other administrative personnel in the company. It has no rear echelon. All members of the company are qualified parachutists and accompany the unit into combat.

■ 70. ARMAMENT AND EQUIPMENT.—During descent all members of the command group carry the same equipment as members of the rifle squad.

■ 71. MISSIONS AND ORDERS.—*a.* Owing to lack of centralized control during the initial phase of a parachute operation, and need for prompt action on the part of all units, the mission assigned to a parachute company usually requires independent action in the first phase of combat. When the company has taken its initial objective, or has reached the assembly area prescribed in the battalion order, its action is coordinated with that of the remainder of the battalion, either by provisions of the initial battalion order or by subsequent orders of the battalion commander.

b. The company commander assigns appropriate tasks to his subordinate units, being careful to leave to his subordinate leaders the utmost freedom of action consistent with the mission and the situation. In assigning these missions, he must take into consideration the difficult communication problems that confront the smaller parachute units in the initial stages of combat, and employ mission type orders.

c. In some situations the company commander can plan his operation and issue his initial orders in great detail. It is essential that provision be made for all contingencies that can reasonably be foreseen. As indicated in subparagraph *b* above, his orders to subordinate units must not, however, impose unnecessary restrictions upon the junior leaders nor attempt to control their actions too far into the future.

■ 72. DUTIES OF THE COMPANY COMMAND GROUP.—Duties prescribed in FM 7-10 for individuals of a rifle company command group apply generally to corresponding members of a parachute company command group. All members of the command group accompany the commander and perform such duties as he directs.

■ 73. DUTIES OF THE PARACHUTE COMPANY COMMANDER.—The parachute company commander performs the duties prescribed for a rifle company commander in a rifle regiment, and in addition is charged with—

a. Supervising the inspections prescribed in paragraphs 56 and 86a and c.

b. Arranging for normal combat supply of his company in accordance with principles and methods stated in this manual.

c. Determining well in advance the need for special equipment and supplies, and making necessary arrangements to get them.

SECTION VIII

PARACHUTE BATTALION

■ 74. COMPOSITION.—The parachute battalion consists of a battalion headquarters and headquarters company and three rifle companies. An 81-mm mortar platoon and a caliber .30 machine-gun platoon are organic parts of the headquarters company. The command group, from the battalion headquarters and headquarters company, is divided into a combat echelon and an administration echelon. The administration echelon includes mess and other rear echelon personnel.

■ 75. ARMAMENT AND EQUIPMENT.—Equipment carried during descent by members of the battalion combat echelon is the same as that carried by individuals of the rifle squad.

■ 76. SUPPLY AND JUMPING TECHNIQUE.—The technique of packing, loading, and dropping equipment and supplies, and of jumping personnel in the various subordinate elements within the battalion, is similar to that prescribed for the rifle squad. (See pars. 49 to 59, incl.)

SECTION IX

PARACHUTE REGIMENT

■ 77. COMPOSITION.—a. The parachute regiment consists of a headquarters and headquarters company, a service company, and three parachute battalions.

b. The composition and functions of the headquarters company correspond in general to the headquarters company of a rifle regiment, except that it contains special facilities to effect demolitions and has no reconnaissance platoon.

c. All motor transportation in the parachute regiment is assigned to the service company. This company also provides personnel and facilities for supply, parachute maintenance, and motor maintenance.

d. The combat echelon of the regimental command group consists of regimental commander, regimental executive, S-2, S-3, communication officer, and necessary enlisted assistants. The administration and supply echelon functions at the base from which the regiment is operating.

e. The commander of the parachute regiment is charged with the duties of a commander of an infantry rifle regiment. See FM 7-40. In addition, he is responsible for parachute activities and maintenance, and training peculiar to parachute troops.

f. If the tactical situation requires, larger parachute forces may be formed by the grouping of several parachute regiments.

SECTION X

MEDICAL DETACHMENTS

■ 78. ORGANIZATION.—*a.* The battalion medical section of a parachute battalion is composed of two medical officers, two noncommissioned officers, eleven company aid men, and two litter bearers. Each member of the medical section is a qualified parachutist.

b. The regimental medical detachment of a parachute regiment is composed of three battalion medical sections, plus a headquarters section which includes the regimental surgeon, a dental officer, an additional medical officer, and sufficient enlisted personnel to handle administration of the detachment and the medical needs of regimental headquarters and the headquarters and service companies.

■ 79. EQUIPMENT.—The detachment has the standard equipment of an infantry regimental medical detachment and, in addition, folding litters. All of this equipment is used in

garrison, but the equipment taken into combat is limited to that which can be dropped by delivery units and carried by the men after it reaches the ground. Two delivery units, type A-5, carry the medical equipment used in combat. These two containers are packed identically. Each contains two aviation kit bags to hold the contents after the container lands, blankets, canteen containing alcohol, small operating case, flashlight, splints, bandages, first-aid dressings, cotton, iodine, a box containing miscellaneous drugs and ampules, and a folding litter. All medical personnel jump with their individual kits attached. As the two pouch kits, medical private, are too bulky and awkward to handle as issued they should be modified as follows: remove the false bottom of one pouch and extend the pouch; pack the contents of the two pouches, with the exception of the book of emergency tags, in this one pouch; carry the pouch on the left side, suspended by a web strap, such as a litter strap, passing over the right shoulder. Attach a thong similar to that on the pistol holster to the bottom, and tie it around the left leg to hold the pouch in place. The book of emergency tags is carried in a pocket of the jump suit.

■ 80. FUNCTIONS.—Functions of the medical detachment in bivouac or garrison are similar to those of any other comparable organization. In combat it functions according to the number of parachute troops employed. If an entire battalion is employed on a mission, one company aid man jumps with each lettered company, and the remainder of the battalion section jumps with the headquarters company. After landing, the equipment is recovered, and a protected area sought for the assembly of wounded and administration of medical treatment. Company aid men tag wounded, give first aid, and direct walking wounded to the aid station. They are reinforced or replaced as necessary by medical personnel with the headquarters company. Litter bearers clear the field of casualties when and if possible. If only one parachute company is committed to action, one medical officer and four enlisted men accompany the company and function in a manner similar to that described for the battalion section.

CHAPTER 3

TRAINING

	Paragraph
SECTION I. General	81
II. Unit training	82-84
III. Jumpmaster	85-86

SECTION I

GENERAL

■ 81. PHASES OF TRAINING.—Training of parachutists is divided into four phases: basic training, individual technical parachute training, unit training, and combined training. The basic training of a parachutist corresponds to that of all infantry soldiers and is normally given at an infantry replacement training center. Because of special equipment and matériel required for individual technical parachute training, this phase normally should be conducted at the parachute school or parachute training center. (See ch. 7.) Combined training of parachute troops, air force elements, and air landing troops will be conducted at every opportunity. (See par. 8.)

SECTION II

UNIT TRAINING

■ 82. GENERAL.—Unit training of parachute troops closely approximates that of rifle regiment units of comparable size, particularly in mechanical training with weapons, range practice, combat principles, and the basic training subjects. It differs principally in that all parachutists must be qualified to handle all platoon weapons, and receive training in such specialized subjects as care, maintenance, and packing of the parachute, and parachute jumping. In addition, parachute troops must be trained in executing demolitions. The men most proficient in this subject are available for use on special demolition missions. Concurrently with the technical

and tactical training of parachute units, an intense and continuous physical training course must be conducted. This training tends to minimize the number of landing injuries and prepares the unit for arduous field service normally incident to parachute operations. When the training of a parachute unit is sufficiently advanced, joint training should be undertaken with air corps units, first with transport units flying in tactical formations, and later with both transport and supporting combat units. Problems of reconnaissance, transport of troops, liaison, supply, preparation bombing and machine-gun fires, and continuous support during ground operations can be solved only by joint training during the advanced training phase. Parachute units should also train with air landing troops, since they will usually work with these units in combat.

■ 83. **PACKING.**—All parachutes are packed under supervision of the unit parachute maintenance officer. Each individual packs his own parachute. Those for delivery units are packed by personnel detailed for the purpose.

■ 84. **DELIVERY UNIT DRILL.**—*a.* The drill consists of repeated practice in handling parachute delivery units before, during, and after jumping, until a satisfactory degree of speed and accuracy is attained.

b. Delivery unit drill before jumping consists of loading, packing, and rigging delivery units. It is an operation which requires precise attention to detail, as well as facility and speed in handling different types of parachute equipment. A special type of rigging known as a "daisy chain" may be employed for delivery units which are to be thrown manually from a door or bomb bay. This is a definite time saver, since three equipment bundles may be thrown from the plane at once with little danger of fouling the plane surfaces. The method of rigging a "daisy chain" is illustrated in figure 14.

c. Delivery unit drill during jumping requires no special training other than that normally given to jumpmasters.

d. Delivery unit drill after jumping consists of constant practice in securing proper equipment and moving to a previously designated assembly area. This is repeated until a satisfactory rate of speed is attained. For competitive pur-

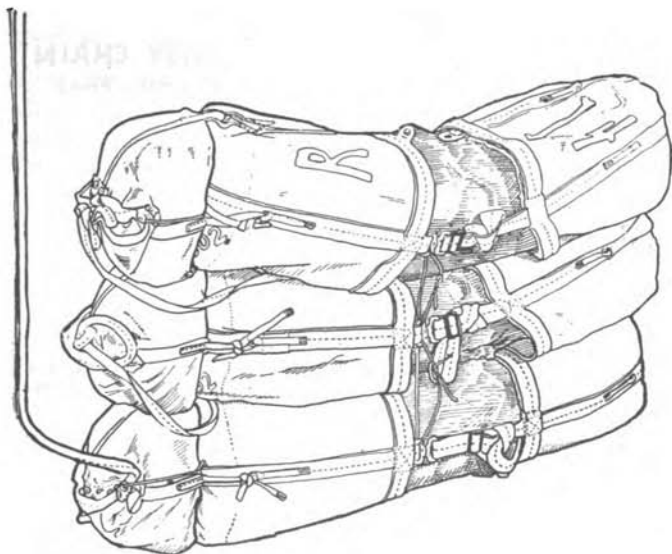

FIGURE 14.—Three A-5 aerial delivery units rigged for "daisy chain" drop. Only one static line is attached to anchor cable.

poses, the equipment for one squad may be left on the ground exactly as it lands. Each squad in turn may be jumped from a position over the equipment, and upon landing each man obtains his equipment and assembles on the squad leader. Time is computed from the moment the first man leaves the plane until the last man joins the squad. Numerous variations, including actual firing after arrival at assembly area, may be employed to add interest to the drill.

SECTION III

JUMPMASTER

■ 85. DEFINITION AND DUTIES.—A jumpmaster is any officer or noncommissioned officer designated to go aloft and control the jumping of men or dropping of equipment from a transport plane. The jumpmaster is responsible for inspections of

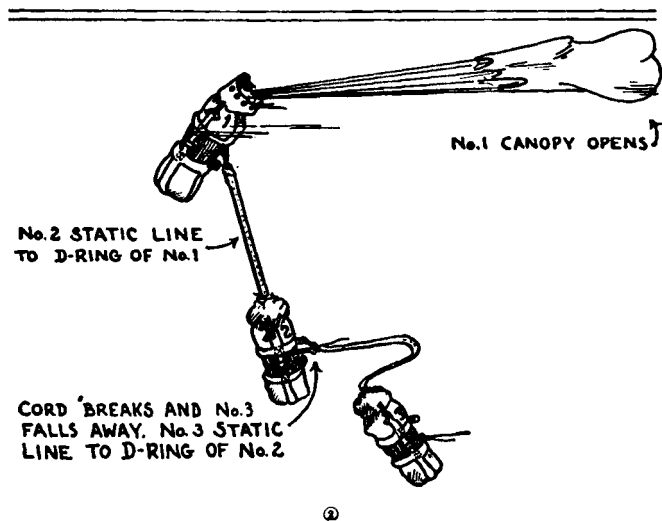
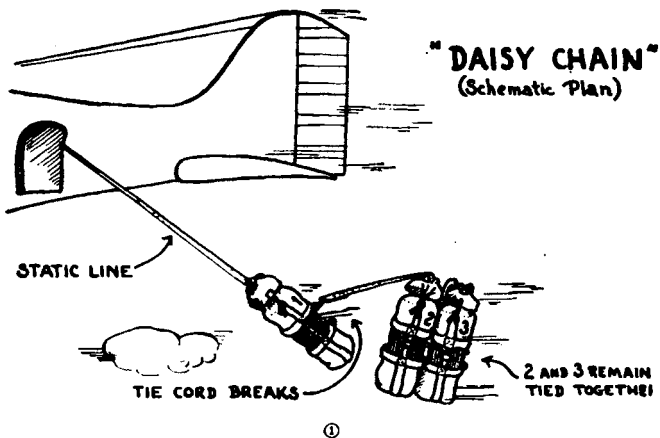

FIGURE 15.—Operation of a "daisy chain."

the plane, men, and equipment prior to the take-off on any mission.

■ 86. INSPECTIONS.—*a. Plane inspection.*—The jumpmaster will make an inspection of the plane assigned him to insure that—

(1) The static line anchor cable is serviceable, and in particular that—

(a) The forward and rear cable bracket attachments are properly secured to the fuselage of the plane.

(b) The braiding of the cable at both brackets is in good order and is not frayed or weakened.

(c) The wrapped cord jacket covering the cable braiding is not so worn that it fails to protect the braiding. (When necessary the braided section is rewrapped by the plane's crew chief.)

(d) There are no frayed or broken strands in the cable itself.

(e) All attachments between cable and fuselage, other than the anchor brackets, are removed.

(2) When the passenger door is to be used for exit of men or equipment, that—

(a) The emergency release attachment on the right side of the door is removed, complete with hinges.

(b) The inside passenger door locking handle on the left side of the door is turned to the "open" position, secured in that position by means of wire, and the handle and wiring are completely and smoothly covered with masking or friction tape.

(c) The exterior door locking handle is completely and smoothly covered with masking or friction tape.

(d) All other door projections are covered with masking or friction tape.

(3) When the passenger and cargo doors are removed, all projections are covered and the hinges of the cargo door removed.

(4) The tailwheel assembly has the projections of the axle and any bolt projections covered by masking or friction tape so as to present smooth surfaces on which parachutes will not foul.

(5) All seats on the plane are secured to the floor and safety straps are in good order.

(6) All loose equipment such as steps, mechanics' kits, and ropes are removed from the rear portion of the plane near the door, and are either removed from the plane, placed in the storage compartment, or secured forward out of the jumper's way.

(7) Any rubber matting on the floor of the plane in the door area is securely cemented and immovable. (If such rubber matting is lying loose on the floor it will be removed until drops or jumps have been completed.)

(8) No men or equipment are taken aloft for drops or jumps until all defects found have been corrected.

b. Personnel inspection.—(1) Each jumpmaster will have a jumpmaster's check list in his possession. Prior to enplaning and prior to jumping he is responsible for the inspection of the equipment of all personnel to jump, as indicated on the following check list:

JUMPMAS-TER'S CHECK LIST OF PERSONNEL

(a) *Prior to enplaning.*

1. Snug harness properly adjusted.
2. Fasteners snapped.
3. Shoulder adapters properly adjusted.
4. Back strap adapters properly adjusted.
5. Static line:
 - (a) Snap fastener and locking pin.
 - (b) Retaining loop.
 - (c) Over shoulder.
6. Reserve parachute:
 - (a) Riser snaps secured.
 - (b) Rip cord pins.
 - (c) Elastics and pack tabs.
7. Body strap secure.
8. Static line loops on back pack.
9. Junction of static line and pack cover.
10. Pack cover lacing.
11. Riser tacking.
12. Feel over entire pack.

(b) *Prior to jump.*

1. Before the command HOOK UP:
 - (a) All harness fittings secure.
 - (b) Reserve pack secure.
 - (c) Static line over shoulder.
2. After the commands HOOK UP and IN DOOR:
 - (a) Snap fastener on cable with pin inserted.
 - (b) Static line over shoulder.
 - (c) Static line away from head.
 - (d) Position of jumper in door.

(2) Prior to enplaning all personnel will be checked to ensure that their physical and mental conditions are such that they may be permitted to jump. Any individual giving any indication of being sick or not mentally alert will not be allowed to enplane. A report of the fact will be made to the individual's organization commander. Such individuals will be sent immediately to the surgeon for examination.

c. Equipment inspection.—(1) Regardless of the packing and assembly source of any equipment containers, the jumpmaster will check containers prior to going aloft, to see that all connections are correctly made.

(2) When dropping containers individually, the jumpmaster will insure that—

(a) Parachute pack assembly is securely and correctly connected to the container.

(b) The static line attachment is correct.

(3) When dropping equipment containers by the "daisy chain" method, the jumpmaster will insure that—

(a) Individual parachute pack assemblies are securely and correctly connected.

(b) Static line attachments between containers are correct.

CHAPTER 4

SUPPLY OF PARACHUTE UNITS

■ 87. RESPONSIBILITY.—*a.* Supply is a responsibility of command which cannot be delegated.

b. When parachute units are attached to divisions or larger commands, the division or higher commander is responsible for the supply of these units. In such cases the commander of the parachute troops is responsible that the higher commander is kept fully informed of the supply requirements of the parachute troops.

■ 88. ORGANIZATION.—*a. Group.*—A parachute group headquarters may be organized to provide the necessary commissioned and enlisted personnel for the tactical and administrative handling of several parachute regiments operating as a parachute group.

b. Regiment.—(1) With the exception of battalion messes, all supply functions within the parachute regiment are under direct regimental control. All personnel for these duties are provided in the service company.

(2) The regimental S-4 performs the duties of the S-4 of a rifle regiment and in addition is responsible for supervision of the operations of the parachute maintenance section of the service company.

c. Battalion.—Normally, the parachute battalion has no administrative or supply functions other than operation of the battalion mess. Personnel for operation of the battalion mess are provided in the battalion headquarters company. When the battalion is to operate alone, a battalion S-4, together with necessary personnel to assist him in effecting supply of the battalion, are attached to the battalion from the service company.

■ 89. PROCEDURE PRIOR TO COMBAT.—*a.* Upon receipt of a warning order for employment of parachute units, the S-4 will immediately contact the G-4 of the higher headquarters and inform him of probable supply requirements of the parachute regiment for the operation. Requirements will vary with each operation.

b. When the S-4 of the parachute unit arrives at the base of operations (see par. 43f), he immediately takes the following steps:

- (1) Visits G-4 and confirms or amends prior arrangements made for delivery of ammunition and rations.
- (2) Visits the quartermaster, ordnance officer, and any other supply officers concerned, and acquaints them with the supply status of the parachute unit.
- (3) Issues instructions to units for the reception and preparation of ammunition for dropping.
- (4) Prepares and submits his supply plan to his commanding officer. This plan will include the following:
 - (a) Allocation of ammunition and containers (or ammunition sling assemblies) to be dropped initially by companies.
 - (b) Method of loading and dropping extra ammunition.
 - (c) Method of collecting extra ammunition dropped, other than that transported and dropped with the companies.
 - (d) Establishment of ammunition distributing points.
 - (e) Method of supplying ammunition forward from ammunition distributing points to companies.
 - (f) Provisions for rations to be carried by personnel.
 - (g) Method of further ration supply.
 - (h) Tentative locations of distributing points.
 - (i) Arrangements for subsequent supply of ammunition, rations, and water from the base, in case the operation is prolonged beyond the estimated period.

■ 90. PROCEDURE IN COMBAT.—a. Unit S-4's supervise execution of the supply plans of their respective units, making changes as necessary, and report these changes to their commanding officers.

b. Each S-4 must inform his commander periodically of the status of supply.

c. Unit commanders report immediately locations and quantities of captured enemy ammunition. Disposition of this ammunition is directed by the senior commander on the ground.

■ 91. PROCEDURE AFTER COMBAT.—S-4 of the parachute command informs S-4 (or G-4) of relieving troops of the locations of any captured enemy stores which have not been disposed of at the time of relief.

CHAPTER 5

TACTICAL EMPLOYMENT OF PARACHUTE UNITS

	Paragraphs
SECTION I. General	92-94
II. Sequence of operation.....	95-106
III. Operations to secure landing areas.....	107
IV. Signal communication.....	108-118

SECTION I

GENERAL

■ 92. PARACHUTE BATTALION.—The parachute battalion is the basic tactical unit of parachute troops. It can enplane in one area under immediate control of the battalion commander, fly to its objective in one formation and jump into a single area. It can jump into a restricted area averaging 700 by 1,000 yards in size. Its elements can jump in any order the situation and circumstances permit. Its subordinate units can jump successively into the same area, obtain arms and equipment, and start on their missions promptly provided the enemy opposition is slight. When two battalions jump into the same area considerable confusion and loss of time will result unless the preceding battalion is given sufficient time to clear the area. It is more satisfactory to give separate areas to each battalion.

■ 93. PARACHUTE REGIMENT.—*a.* Upon receipt of orders from higher headquarters, the regimental commander assigns each battalion its mission and an area in which it can jump in order to accomplish its mission. These areas are usually sufficiently large to provide several possible jump areas, the exact area being left to decision of the battalion commander. Generally, the area assigned by regimental order will be far enough from the enemy's defensive establishments to minimize the effects of his small-arms fire, yet close enough to the objective to permit rapid action against it.

b. A battalion or larger unit may be given the mission of drawing troops away from an objective to increase its vulnerability to the main parachute attack which will follow later. The battalion may or may not land near its objective, but in either event its action should be such as to cause diversion of the defending troops from the objective.

c. Several parachute regiments may be used in one large scale attack. Jump areas of each unit and the timing of the jumps and action of each parachute unit on the ground are coordinated by the task force commander to accomplish the desired mission.

■ 94. HOUR OF ATTACK.—The time at which a unit is to jump depends to a large extent on the mission and the enemy dispositions. The greatest surprise can be obtained by jumping at dawn. However, jumping at such a time sacrifices preliminary supporting fires which otherwise might be furnished by supporting aircraft. If the jump is to be preceded by an intensive bombardment by supporting aircraft, the jump will have to be made during daylight hours. Occasionally, a mission may require a unit to jump at dusk in an area remote from enemy defensive establishments. Under cover of darkness the unit may then move and be prepared to make a dawn attack in conjunction with an air attack, or move on any other task the mission may require. For special missions, well-trained parachute troops can jump at night under favorable conditions of moonlight without experiencing an unusual number of jump injuries. However, after landing they are subject to the usual difficulties of control experienced at night by ground troops.

SECTION II

SEQUENCE OF OPERATION

■ 95. RECONNAISSANCE.—Upon receipt of a tentative mission from the task force commander, the parachute unit commander should take immediate steps to learn the nature of the terrain into which his unit must jump to accomplish its mission. Intelligence reports which provide information of enemy dispositions should be studied concurrently with analysis of the terrain. Meteorological reports should be used to predict possible weather conditions and determine

prevailing winds in the jump areas. Requests for aerial photographs should be made without delay. These are most important and valuable. If possible, vertical photographs should be taken at 5,000 feet and 10,000 feet, and enlarged to 18 by 24 inches. These are invaluable in instructing jumpmasters and unit commanders in their tasks. Oblique photographs taken in the direction of approach to the jump area are also of considerable help to jumpmasters and pilots. Aerial photographs, in addition to providing knowledge of probable jump areas and jump hazards, also provide information of enemy dispositions. During the reconnaissance phase, every possible source of information of the enemy and enemy terrain should be exploited.

■ 96. PLANNING.—Concurrently with the reconnaissance phase, steps should be initiated by the commander of the parachute troops to procure any special arms and equipment necessary for the task at hand, and to train personnel in their use. Missions will frequently require special demolition equipment or specially organized demolition units. The operation may require special communication equipment. The mission may necessitate considerable entrenching equipment. No parachute unit is organically equipped for every tactical contingency that may arise. Early in the planning phase, therefore, the unit commander concerned should make sure that his unit is properly organized and equipped for the particular mission at hand.

■ 97. SAND TABLE.—A sand table reproduction of the jump area should be prepared from aerial photographs and maps. Experience has proved this to be an exceptionally valuable method of familiarizing everyone concerned with their detailed duties and responsibilities. All orders to subordinate parachute unit commanders should be issued at the sand table. A line showing the direction of flight and the jump line may be drawn on the table. These are discussed during jumpmaster-pilot conferences held at the table. Many men who lack the training or imagination necessary fully to appreciate map symbols readily visualize and remember terrain features shown on a sand table.

■ 98. LIAISON.—*a.* The parachute unit commander should establish liaison at once with commanders of the air transport unit, the supporting combat aircraft, air landing troops, and commanders of any other ground or naval forces which are to participate in the operation. This liaison may be arranged by the task force commander. All participants must have a definite understanding and appreciation of the many problems likely to arise. Timely conferences will obviate many later difficulties.

b. An Air Force officer should be assigned to headquarters of each parachute group and parachute regiment for liaison purposes.

c. A parachute liaison officer should be assigned to headquarters of any air landing troops participating in the operation.

■ 99. FLIGHT FORMATION.—*a. For jump.*—(1) Responsibility for the formation for the jump rests with the parachute commander. The parachute unit commander first decides upon the jump area to be used. Then, after conferring with the air transport commander and the air liaison officer, he decides upon the formation the air transports should employ during the jump. This decision is based upon a consideration of the size of the jump area, mission, number of air transports, and anticipated enemy resistance. When all transports have equipment racks, any formation may be employed which satisfies the particular requirements of a given situation and which provides reasonable safety for both parachutists and pilots. When some of the transports do not have equipment racks, the following type formation is satisfactory:

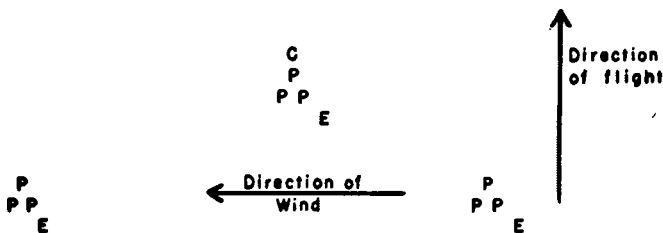

C=Command plane (may be anywhere in formation).

P=Personnel plane.

E=Equipment plane.

In the above formation pilots try to maintain an interval of 100 feet from wing tip to wing tip. They may have to vary this interval considerably. The distance between flights of 4 ships is usually about 1,000 yards, or 20 seconds. These distances and intervals are merely guides. They may be modified to suit conditions, such as weather, terrain, and need for protection by combat aviation.

(2) A diagrammatic chart should be prepared by the parachute operations officer showing the place of each ship in the flight. This should be placed on the parachute unit operations blackboard, and on it, whenever possible, should be shown the names of the pilot and the jumpmaster with each ship. It should be used at all pilots', jumpmasters', and unit commanders' conferences.

b. En route to jump area.—Responsibility for the formation from take-off area to jump area rests with the air task force commander. There are two methods of flight. One method is to fly at a low altitude, with a climb to about 300 feet at the jump area. This method has the following advantages: protection from antiaircraft fire, concealment protection from high flying pursuit planes, sudden appearance at the jump area, and possible selection of a route over relatively uninhabited areas to avoid giving warning of the attack. It has the following disadvantages: navigation at a low altitude is difficult; no opportunity exists for selection of an emergency landing field; parachutes cannot be used in event of an emergency. The second method is to fly at a high altitude, gliding to about 300 feet at the jump area. This method has the following advantages: use can be made of available cloud cover; parachutes may be used in an emergency; navigation is simplified. It has the following disadvantages: the formation is vulnerable to antiaircraft fire and enemy pursuit planes; high formations are easily spotted both from the air and from the ground.

■ 100. FLIGHT SECURITY.—Security during the flight from take-off area to jump area will be provided by supporting

combat aviation. This supporting aviation may be provided from the take-off area or may be picked up en route to the jump area at a rendezvous over friendly territory. Arrangements for support and security are made through the task force commander or directly with the commander of supporting aviation, as provided in the plans for the operation.

■ 101. JUMPMAS-TER-PILOT CONFERENCES.—a. In many situations the success or failure of a parachute unit in accomplishing its mission will depend upon whether or not pilots and designated jumpmasters working as teams can place the parachutists in the exact area desired. Equipment dropped in dense woods or in water, and jump casualties caused by poor judgment on the part of the jumpmaster are a definite loss. All jumpmasters are responsible for the inspection of jumpers in their planes and must determine the exact instant that they are to jump. The jumpmaster in the leading plane of each formation (usually a formation transporting a company) has the added responsibility of determining the location over which jumps are to begin. Based on his decision, and by observing when the jumpers in his plane begin to leave that plane, or on signal, the jumpmasters in following planes determine when their jumps are to begin.

b. Correct performance depends upon complete cooperation between jumpmasters and pilots of leading planes in formations, and upon the pilots and jumpmasters of following planes conforming to the actions or signals of the leaders. The jumpmaster of the leading plane is responsible for directing the pilot onto the desired approach during the last few miles to the field. This jumpmaster and his pilot must work as a team and without friction. They must both realize that, while the pilot is responsible for navigation, for safety of the ship, and for maintenance of formation, all these are incidental to placing the ship over the spot desired by the jumpmaster. The pilot and jumpmaster both estimate wind conditions on the ground and aloft by observing trees, the action of the plane, drift of smoke and dust, and similar indications. Since many of their duties overlap, it is all important that they cooperate fully, and for this reason a jumpmaster-pilot conference must be held at which the

projected operation is discussed in detail to eliminate any misunderstanding that might exist. All jumpmasters and pilots attend this conference, including those to be in planes other than the leading plane of each formation. All must know in detail the intent and spirit, as well as the letter, of orders issued for the operation planned.

■ 102. JUMPMASTER-PARACHUTE UNIT COMMANDER CONFERENCE.—The purpose of jumpmaster-parachute unit commander conferences is to familiarize all leaders with detailed tactical plans and orders for the operation. Frequently, these conferences are combined with jumpmaster-pilot conferences, since some of the jumpmasters are also unit commanders. Because of the great responsibility resting upon the jumpmaster of the leading plane of the leading flight, it is customary for him not to jump.

■ 103. REHEARSAL.—*a. General.*—Every advantage will accrue to the unit which rehearses its planned operation. When time permits, a particular operation should be rehearsed until every jumpmaster, pilot, unit commander, and other participant knows his particular task thoroughly. Rehearsals afford an opportunity for the parachute unit commander to test each individual in his knowledge of his particular duty in the coming operation, and to correct deficiencies. The area selected for the rehearsal should resemble as closely as possible the proposed combat area.

b. Pilots and jumpmasters.—Under direction of their immediate group commander, pilots first practice formation flying and approaching the jump area. Jumpmasters then accompany pilots in practice approaches and jumps, using dummies which are recovered later. When the jumpmaster-pilot team has attained a satisfactory state of proficiency and troops have finished their ground training, live jumping begins. (See *c* below.)

c. Troops.—Concurrently with preliminary pilot-jumpmaster training, troops pursue a course of special instruction in solution of the tactical problems which they expect to encounter in combat. When they are well qualified in this ground work, they are jumped under conditions approximat-

ing those in the combat area. Supporting combat aviation should be present in this jumping phase to rehearse with the parachute units such details of air support for the operation as can be anticipated.

■ 104. ACTION PRIOR TO ENPLANING.—The commander of the air task force will furnish the parachute unit commander an airplane parking diagram, to obviate confusion and facilitate expeditious loading. This should be placed on the parachute unit's operations blackboard. If time permits it should be reproduced in mimeographed form and distributed to unit commanders. Timely reconnaissance of the enplaning area by parachute unit commanders should enable them to avoid any difficulties or confusion in the loading of equipment and personnel.

■ 105. ACTION EN ROUTE.—The jumpmaster-pilot team functions as outlined in the preceding paragraphs. The parachute unit commander with the combat echelon selects the part of the flight in which he will fly and from which he will jump. Ordinarily he should jump with the leading flight.

■ 106. ACTION ON THE GROUND.—Individuals obtain equipment and unit leaders regain control as quickly as possible after landing. This is usually accomplished through the use of previously selected assembly areas. Thereafter, the unit acts in accordance with the mission assigned. Speed in obtaining equipment and organizing into combat units is essential.

SECTION III

OPERATIONS TO SECURE LANDING AREAS

■ 107. OPERATIONS OF PARACHUTISTS.—*a.* It must be expected that any airport or area suitable for landing of transport planes will be defended. Parachutists who attempt to seize a defended airport by landing on it will probably suffer heavy casualties which might be avoided by landing outside the airport and launching an attack against it.

b. Exact locations of landings for parachute troops are dependent on many factors. Landings should be made at several points and so timed as to draw part, or all, of the

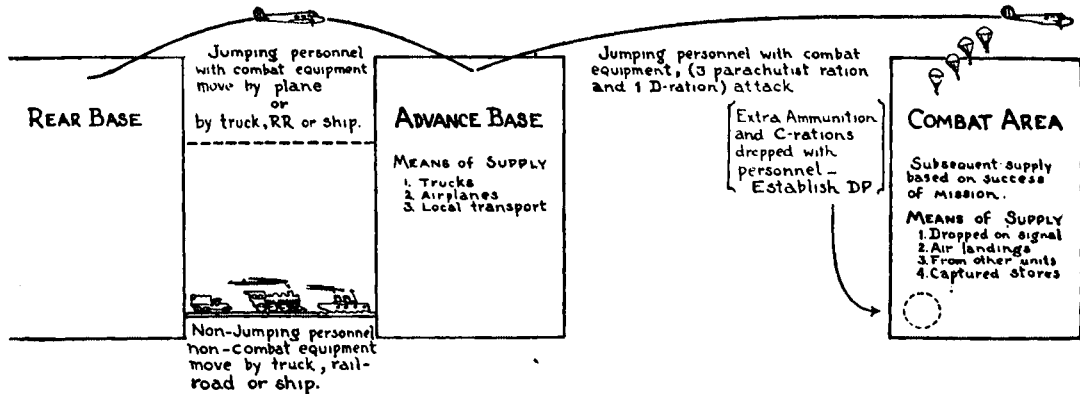

FIGURE 16.—Parachute operations.

mobile antiparachute troops away from the objective. If the airport is dominated by nearby terrain, seizure and retention of this terrain will contribute to the final seizure of the airport. If more than one suitable airport exists, several should be attacked, and the attack showing the most promise of success should be reinforced until an airport has been secured.

c. Seizure of an airport should not be considered successful until it has been freed from small-arms fire, ground-observed artillery fire, and hostile troops. Plans should provide that, in the initial jump, certain parachute units have the specific missions of destroying enemy antiaircraft artillery batteries and capturing areas believed to be occupied by enemy field artillery batteries protecting the airport. An attack to capture an airport which is well organized for defense will require detailed planning, thorough execution and, above all else, parachute troops in sufficient numbers, equipped, organized, and trained for the specific operation. If the area to be seized is an area other than a regular airport, but suitable for the landing of air transports, such as a wide paved road, a level clearing, or a beach, it may be practicable for parachute troops to land directly on the area to be seized. When such an operation takes place, the first parachutists to jump are given missions of establishing outposts blocking all approaches to the area. Transportation facilities are immediately seized, enemy communications destroyed or seized for our own use (see par. 117), and any necessary clearing of the area of landing obstacles undertaken. Captured transportation is used to reconnoiter the vicinity of the landing area and to establish contact with parachute units which may have landed in another area in the same operation. Such transportation can be used later by air landing troops for moving weapons, ammunition, and personnel. Captured transportation must be promptly marked for identification to prevent its being fired on by friendly troops. These identification marks must be understood by all parachutists.

d. Communication with the rear is most important, and all practicable means should be employed for its establishment. Antiaircraft protection for the landing area, either

improvised or planned, should be established immediately. Prompt, aggressive action on the part of parachute troops is imperative. The critical period between the time the first parachutists leave their planes and the time that the air landing troops arrive should be reduced to a minimum consistent with the tactical practicability of landing transports in the area seized.

SECTION IV

SIGNAL COMMUNICATION

■ 108. **GENERAL.**—Signal communication in parachute units is basically as set forth in the following documents: FM 11-5, Mission, Functions, and Signal Communication in General; FM 11-10, Organization and Operations in the Infantry Division. Technical details for training of personnel in the installation, operation, and maintenance of signal communications are contained in FM 24-5. Much of the communication technique outlined for air landing units in part I is equally applicable to parachute units. (See par. 20.)

■ 109. **RESPONSIBILITY.**—The commander of each unit down to and including the platoon is responsible for establishment of signal communication within his own unit and with supporting aviation and other units as directed by higher authority. The actual execution is usually delegated, but the responsibility remains wholly that of the unit commander. Continuous functioning of communication is essential to the accomplishment of every parachute mission.

■ 110. **MISSION.**—The mission of the various communication teams is to furnish necessary channels of communication to effect preparations for combat and facilitate execution of the actual combat mission. This is accomplished by—

a. Installation, operation, and maintenance of a communication system at the rear base.

b. Setting up direct radio contact from the rear echelon to the combat echelon, and arranging for as many alternate means of communication as possible with the equipment provided.

c. Maintaining a complete communication system within the combat echelon.

d. Maintaining communication from the combat echelon to supporting aviation and other supporting or cooperating units in the combat zone.

■ 111. ORGANIZATION.—For detailed organization, see Tables of Organization. In general, each platoon, company, battalion, and regiment has its own organic communication personnel. The regiment is the only unit which has personnel to operate communication facilities in the rear and combat echelons concurrently.

■ 112. COMMUNICATION OFFICER.—Each battalion and regiment has its own communication officer. The communication officer acts as a staff officer and also commands the communication platoon of his unit. In addition to his command duties, he is responsible for technical and tactical supervision of signal communication within subordinate units and for maintenance of efficient signal communication within his own unit. He is prepared to furnish his commanding officer with information and advice on all questions affecting signal communication.

■ 113. COMMAND POSTS.—The command post should be located so as to be safe from hostile fire and sufficiently close to the unit it serves to facilitate control. While the command post is moving, communication within the unit is maintained by means of portable radio equipment and messengers. Axes of signal communication should be prescribed for battalions and, when practicable, for companies.

■ 114. MEANS OF COMMUNICATION.—The means of signal communication used by parachute troops are radio, visual (lamps, flags, panels, and pyrotechnics), messengers, pigeons, and sound-powered telephone equipment, type TE-11. Radio is the primary means of communication. Means of communication between aircraft and ground units include dropped and pick-up messages.

■ 115. EQUIPMENT.—For quantities and types of equipment see Table of Basic Allowances No. 7.

■ 116. TACTICAL EMPLOYMENT OF SIGNAL COMMUNICATION.—*a. Radios.*—Radios are usually employed as shown in figure 17. Within units radio communication is continuous. Both clear and coded messages may be employed with due regard for secrecy. Frequency assignments for the several nets are usually prescribed by higher headquarters. Frequencies are coordinated with air landing troops, supporting aviation, other supporting forces, and higher headquarters. The rear area command frequency is assigned by the task force commander. Aircraft relay from front to rear is a supplemental channel of radio communication.

b. Visual.—Visual signals are suitable for transmission of short prearranged messages. They should not be used when they are likely to disclose a position, draw fire, or when the signal may be read and understood by the enemy.

c. Air-ground communication (other than radio).—Use of panels is limited to a few prearranged signals. Units authorized to designate targets to supporting aircraft do so by means of prearranged panel or pyrotechnic codes. Signal lamps may be used for communication with some types of planes.

d. Messengers.—Messengers are a vital link in the communication system. Selection and training of messenger personnel should be stressed. Frequently, bicycles or light motorcycles are used. In rear areas motor messengers are used. Arrangements should be made for messenger planes to shuttle between the combat and rear echelons. These planes may deliver messages by radio, by dropping them, or by landing, and may receive them by radio, pick-up panel, signal lamp, pyrotechnics, or by landing. Night use of messenger planes on prearranged schedules is sometimes practicable.

e. Pigeons.—(1) Homing pigeons are used by forward combat echelons for carrying messages to the base headquarters. Available facts pertaining to the enemy situation should be reported to the higher command with each pigeon message. Pigeons and pigeon equipment may be obtained by commanding officers of parachute troop units by arrangement with the signal officer of the division or other unit to which the parachute troops are attached.

(2) The headquarters to which messages are dispatched and the location of the sender should be clearly indicated

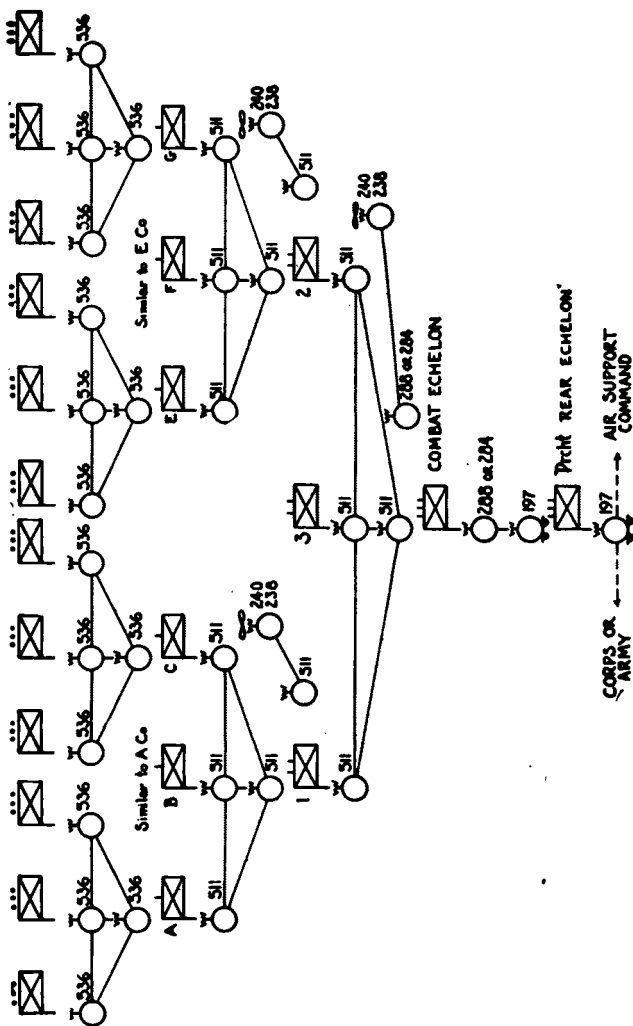

FIGURE 17.—Type radio nets, parachute regiment—schematic only.

in code on each message sent. A duplicate copy of a message previously sent may be dispatched on another pigeon to insure its delivery. Pigeon messages issuing from each parachute command should be numbered consecutively for each 24-hour period. The date should be clearly indicated. For technique of handling pigeons, see FM 24-5.

■ 117. ENEMY SIGNAL COMMUNICATION.—Parachutists cut enemy wire installations and destroy other communication equipment as a matter of standard practice. Temporary disablement of enemy installations or seizure for our own use should be carried out by specially trained personnel. Wire tapping and like activities should also be performed by specialists. Organic communication personnel are not usually employed for these missions.

■ 118. DELIVERY OF COMMUNICATION EQUIPMENT.—The standard equipment delivery unit, type A-5, without modifications, can be used to drop radio and all other communication equipment. Spare communication equipment should be dropped in separate containers and dispersed throughout the unit landing area. This necessitates a dispersal of communication personnel throughout each unit.

CHAPTER 6

COORDINATION

■ 119. **GENERAL.**—Reconnaissance, transport, and combat units of the air forces participate in all tactical operations of parachute troops. Air landing troops usually participate. The commander of the parachute troops must have frequent contact with the commanders of all of these units during the planning and preparatory phases of an operation to insure complete mutual understanding, and to arrange the precise coordination which is necessary.

■ 120. **AIR TRANSPORT.**—Air transport units provide transportation for parachute troops from their base or loading area to the selected jump point and supply these troops with ammunition, food, equipment, and reinforcements in the combat area. For detailed staff data for use in planning such a movement, see FM 101-10.

■ 121. **OBSERVATION AVIATION.**—Reconnaissance and observation aviation constitute means for making a thorough and continuous reconnaissance of the jump area and enemy installations in the vicinity. This is accomplished by taking aerial photographs and flying observers over the jump area. If practicable, the leader of the leading flight of air transports and the jumpmaster of the leading transport should be flown over the jump area during the preparatory phase of the operation.

■ 122. **SUPPORTING COMBAT AVIATION.**—Supporting combat aviation may perform the following tasks:

- a. Gain and maintain air superiority along the route to be followed by transport units with parachute troops.
- b. Gain and maintain air superiority at the objective or jump area.
- c. Neutralize antiaircraft and other ground resistance at the jump area prior to arrival of parachute troops.

d. Protect and cover the landing of parachute troops by attacking ground targets and hostile aircraft. Care must be taken that friendly parachute troops organizing on the ground are not subjected to fire or bombardment from friendly aircraft.

e. Furnish on call or signal close bombing and machine-gun support to parachute troops on the ground.

f. Resupply parachute troops in the field with ammunition and other supplies. The use of supporting combat airplanes for resupply is particularly desirable when the available cargo type aircraft lack fire power.

■ 123. AIR LANDING TROOPS.—If an operation involving both parachutists and air landing forces is contemplated, it is imperative that liaison be established promptly by an exchange of liaison officers between the units concerned. Air landing troops will be particularly concerned with coordination of their arrival with tactical developments of the parachute operations, establishment of contact with parachute units upon arrival, and joint operation and tactical responsibilities of both forces until the parachute forces are withdrawn (see pt. one).

CHAPTER 7

ADVICE TO INSTRUCTORS

	Paragraphs
SECTION I. General.....	124
II. Technical parachute training.....	125-128
III. Equipment.....	129-136
IV. Packing course.....	137-141
V. Jump training course.....	142-148
VI. Tower training course.....	147-151
VII. Qualification jumping.....	152-157
VIII. Equipment drills and additional training.....	158-159
IX. Specialist schools.....	160-164

SECTION I

GENERAL

■ 124. PURPOSE.—The provisions of this chapter are to be regarded as a guide and will not be considered as having the force of regulations.

SECTION II

TECHNICAL PARACHUTE TRAINING

■ 125. PURPOSE.—*a.* The purpose of technical parachute training is to train troops to jump by means of parachutes from a plane in flight and to land without physical injury, so that they can effectively carry out an assigned combat mission.

b. In order to reach this objective the individual will be trained—

(1) In the technique of packing, inspecting, and caring for an individual troop type parachute.

(2) In the principles governing mass tactical jumps from a plane.

(3) In the application of proper principles of landing with a parachute so as to avoid injury.

(4) In the method of loading and ejecting the necessary equipment delivery units.

■ 126. SCOPE.—Within the limitations of time allotted by higher headquarters, and availability of equipment and facilities, the scope of technical training should provide—

a. A thorough course in care and packing of the parachute to insure that each student is—

(1) Capable of packing a troop type parachute for a live jump.

(2) Familiar with the routine of inspection necessary to insure the safe condition of his parachute.

(3) Capable of making minor adjustments necessary to insure proper functioning of the parachute.

b. A thorough course of jump training to include—

(1) Physical conditioning for parachute jumping.

(2) Coordination exercises to teach body control.

(3) Apparatus training to teach the mechanics of parachute manipulation and landing.

(4) Exercises to teach the proper method of exit from a plane in flight.

(5) Parachute tower training, both controlled and free, to acquaint the student with the sensation of descent and free fall, to teach the proper landing attitude, and to permit demonstration of jumping technique by the application of actual free descents in a parachute.

(6) Qualifying jumps from a plane in flight.

c. Instruction and drill in the proper method of loading equipment delivery units, methods of ejecting them in flight, methods of identifying them by markings, and in assembling at equipment delivery units after landing.

d. Instruction in the history of parachute troops, historical examples of their employment, and the general organization of parachute units.

■ 127. CONDUCT OF TRAINING.—a. *Sequence.*—All instruction must progress in a logical manner. For example, packing instruction must progress in simple stages to insure complete familiarity with parachute construction and the mechanics of packing. Similarly, jump training exercises must take into account gradual development of the body muscles to permit execution of difficult maneuvers.

b. *Elimination of fear.*—Fear of jumping by means of a

parachute is based largely on ignorance. The guiding principle of all parachute instruction must be to replace ignorance and resultant fear by thorough knowledge and familiarity with the parachute and confidence in its capabilities. Stressing of the safety features of the parachute has a favorable effect on morale. Questions should be encouraged. Every effort should be made to eliminate the many small groundless fears by a frank discussion of nervous sensations that accompany even the routine jump.

c. Maintenance of interest.—In addition to being progressive both as to scope and degree of physical exertion required, training schedules must be varied so as to maintain interest. Instruction in subjects which are particularly interesting and appealing should be spread throughout the course and interspersed between periods devoted to tasks which lack sustaining interest.

d. Size of classes.—No rule can be given as to size of classes. Equipment and facilities available are the governing factors. As guiding principles, not more than three students should be given instruction at one packing table at a time, and groups should not exceed 50 men at one time for mass exercises conducted on any apparatus.

e. Uniform.—The uniform for training should be appropriate for physical activity involved in the exercise. Qualification jumps should be made in the complete parachute uniform. Fatigue or appropriate athletic uniform should be worn during other jump and tower training. Whenever feasible, schedules should be arranged so as to permit wearing of the dress or drill uniform for lectures and packing instruction.

f. Alertness, precision, neatness, and discipline.—These qualities are indispensable for members of parachute units. All training will be conducted in such a manner as to demand and develop these characteristics.

■ 128. ALLOTMENT OF TIME.—The time required to complete technical parachute training of a soldier will vary greatly, depending upon equipment available, including transport planes, weather, number of instructors, and the aptitude of the individual soldier. The time allotted to this phase of training will normally be determined by higher headquarters. Based

upon a period of one month of 26 eight-hour training days, the following allotment of hours is recommended:

	<i>Hours</i>
Packing instruction.....	52
Jump training.....	52
Tower training.....	36
Equipment drill.....	12
Lectures.....	8
Qualification jumps.....	48

SECTION III

EQUIPMENT

■ 129. GENERAL.—*a.* The following buildings and areas should be available for conduct of technical training:

- (1) Packing building with drying tower.
- (2) Training building with training apparatus.
- (3) Outdoor, smooth surfaced drill field for mass calisthenics and tumbling.
- (4) Cleared flat terrain, about 2,000 yards by 1,000 yards, for parachute jumping.

b. In the selection of a site for technical parachute training consideration should be given to climate and weather conditions so as to permit year around training.

■ 130. PACKING BUILDING.—A packing building should have sufficient floor space to accommodate packing tables, a drying tower, and heating facilities for drying parachutes suspended from the ceiling. It should also have a room for storing packed parachutes in bins, a supply room, a maintenance room, and necessary office space. It should be well ventilated and adequately lighted and heated. The size of the building required will depend upon the number of tables to be installed and the number of parachutes to be accommodated in the drying tower. Floor space 43 feet by 6 feet should be allowed for each packing table desired, to permit comfortable working at the table which is 43 feet by 3 feet. The drying room should provide 9 square feet for each parachute. Bin rooms for storage should provide 12 cubic feet per parachute.

■ 131. TRAINING BUILDING.—The training building should be of gymnasium type with special apparatus built in for training parachutists. In addition to containing apparatus specially designed for parachute training, it should contain stall bars, parallel bars, horizontal bars, ropes, and other standard gymnastic equipment which will encourage students to participate in extracurricular training. Indoor training facilities should include a jumping platform, a suspended harness room, and a door mock-up. Training is facilitated if these rooms are segregated so that instruction can be conducted concurrently in different parts of the same building. Outside facilities which may be considered as part of the training building should include a landing trainer; a "Stafford Metal Trainer" or, in lieu thereof, an improvised climbing trainer; an outdoor jumping platform; and a door mock-up.

■ 132. PARACHUTE TOWERS.—Although parachute towers are not absolutely essential to training, they are most useful. They may be used by the student to make practical application of all the theory of parachute descent which he has learned during his jump training course. Whenever possible a controlled tower and a free tower should be made available for this type of training. The controlled tower should be a 250-foot tower with mechanism and equipment which will permit descent of a captive canopy in a vertical plane. The free tower should permit free descent of an inflated parachute from a height of 250 feet. The minimum height of any type of tower utilized for this purpose should be 125 feet. Of the two types, the free type tower is the more useful.

■ 133. PACKING EQUIPMENT.—*a.* The following equipment is desirable for training personnel in parachute packing:

(1) One parachute table for each group of two or three students. This table should be 43 feet long and 3 feet wide and have a smooth, finished surface. It should be provided with a drawer for storing table equipment. The following tools and equipment are needed for each table:

- 1 tension board.
- 1 extension.

- 1 apex hook.
- 1 folding tool, small.
- 1 folding tool, large.
- 1 packing paddle.
- 3 shot bags.
- 1 needle, harness maker's, #0 or #00.
- 1 wiping cloth.
- 1 needle, lacing.
- 2 strips, pack closing cord.
- 1 troop type parachute for instructional purposes.

(See figs. 18 and 19.)

(2) In addition, the following supplies should be available for each group of six tables:

- 1 spool of thread, linen, left twist, #16-5 cord.
- 1 spool of thread, linen, left twist, #16-3 cord.
- 1 box suspension line retaining bands.
- 1 piece beeswax.

(3) The above listed equipment is sufficient to train a maximum of three students per table.

b. For a complete list of Air Force, quartermaster, and other supplies needed for a complete parachute packing course, see Table of Basic Allowances No. 7-2.

■ 134. JUMP TRAINING EQUIPMENT.—The following equipment should be available in the training building and its immediate vicinity:

a. One suspended harness for each 50 students. This apparatus consists of a regular troop type harness with extended risers $6\frac{1}{2}$ feet from the point of suspension on the shoulder, connected to an iron ring 4 inches in diameter. It may be elevated by means of a pulley or block. A man suspended in this harness, by pulling on the risers, can simulate the mechanics of manipulating the parachute in descent. The apparatus should be capable of elevation so that the student's feet are at least 3 feet above the ground. By placing bungee shock absorber cord in the risers, the student will be given an indication of the pull necessary to effect a canopy change when the canopy is inflated. (See figs. 20, 21, and 22.)

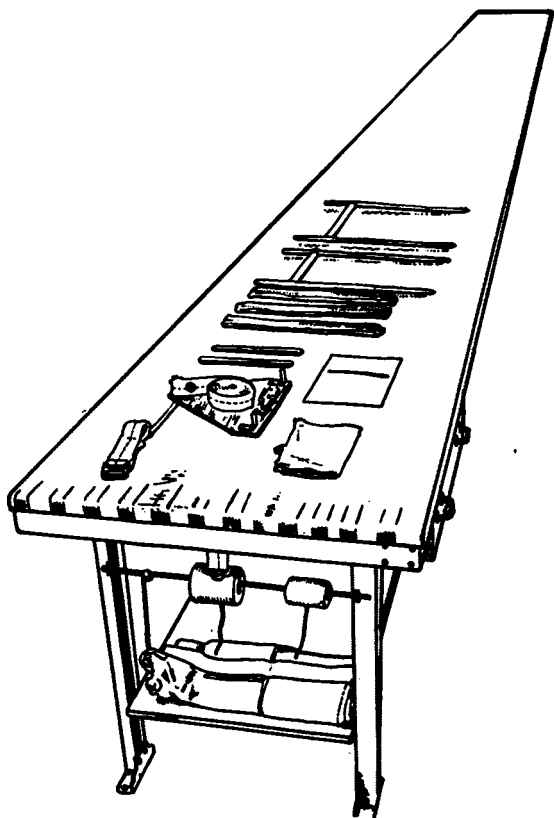

FIGURE 18.—Parachute packing table with packing equipment displayed.

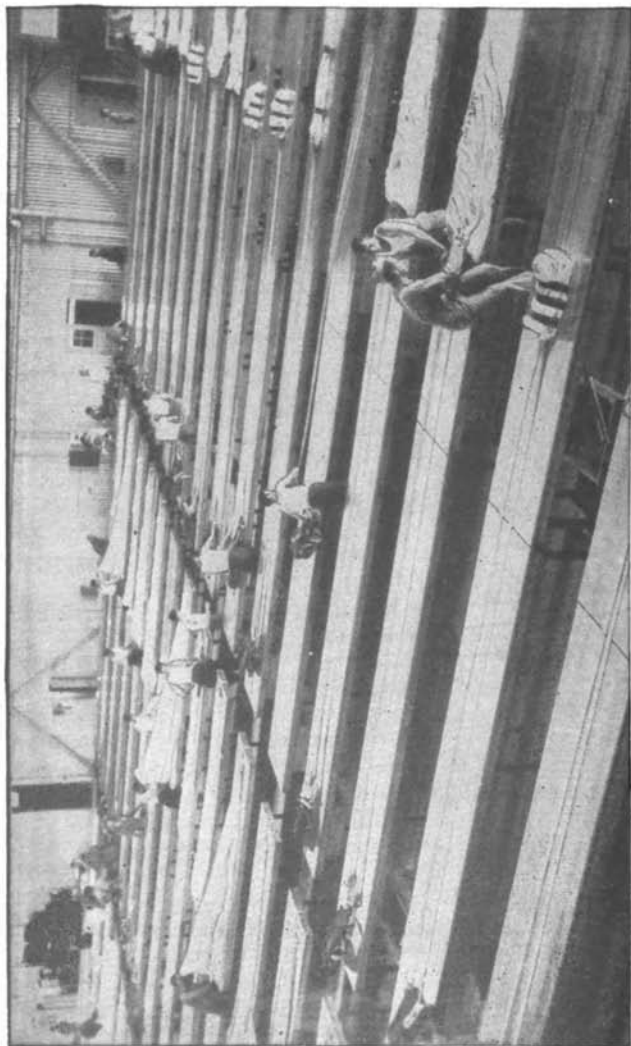

FIGURE 19.—Parachute packing room in operation.

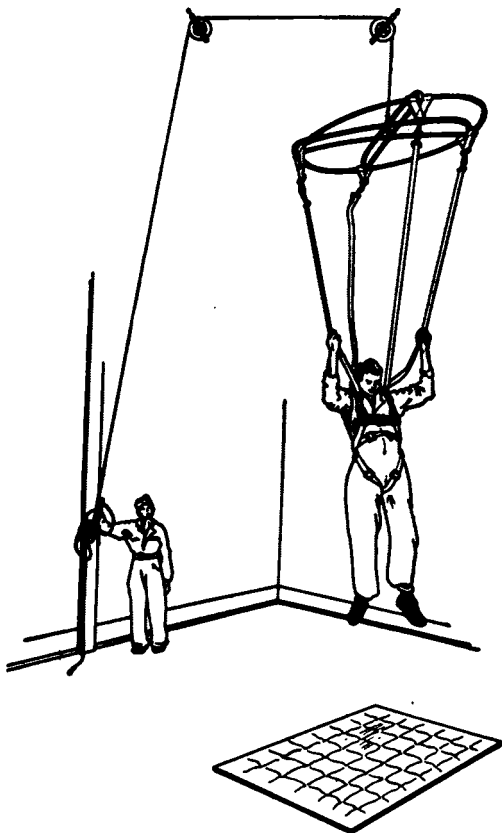

FIGURE 20.—Suspended harness training. Parachutist practicing riser manipulation.



FIGURE 21.—Suspended harness training showing method of grasping risers.



FIGURE 22.—Suspended harness training. Parachutist pulling down sharply at moment of impact with ground.

b. A door mock-up should be available for each 150 students. The door mock-up is a grounded assemblage of the rear two-thirds of a transport airplane. It should be constructed so that the floor level is 3 feet above the ground and should conform to the dimensions and shape of the standard type transport airplane used by parachute troops. It should be equipped with seats and anchor cable. The door mock-up may be used in teaching the mechanics of individual and mass exit from a plane in flight. (See figs. 23, 24, and 25.)

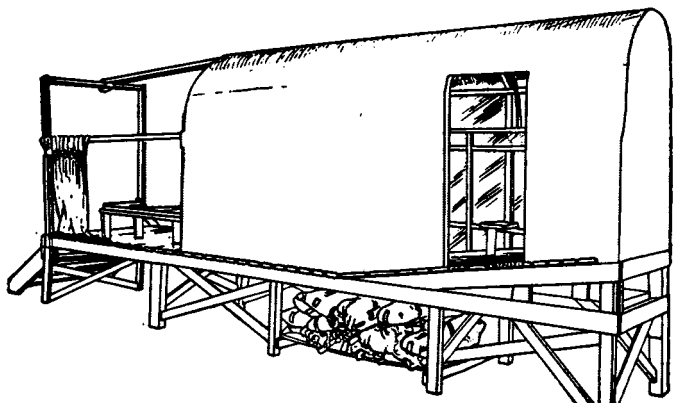

FIGURE 23.—Mock-up of C-33 type airplane.

c. A landing trainer should be available for each 100 students. The landing trainer is a device which enables a trainee to descend from a height with a horizontal velocity and be released automatically at any desired point by an instructor. Thus the trainee is required to absorb the landing shock by rolling. The trainer consists of a 60-foot section of I beam supported by bracing so that it is 16½ feet from the ground at one end and 8 feet from the ground at the other end, giving it an inclination of about 20 degrees from the horizontal. A regular trolley type crane is used to roll along the I beam. A horizontal iron bar is attached to the

crane. This bar is 1½ inches in diameter and 18 inches long. At each end of the iron bar is attached a quick release



FIGURE 24.—Parachutist, wearing dummy parachute, in mock-up door of type C-33 airplane. Correct position for exit.

mechanism to which may be attached a harness with 4-foot riser extensions, worn by the trainee. The trainee, attached to the crane and bar by means of his harness risers and the

quick release mechanisms, is started off from a platform at the higher end of the apparatus, rolls down the inclined



FIGURE 25.—Correct position for making a jump. Side view from interior of "mock-up."

I-beam, and is released when about 1 foot above the ground at the lower end of the apparatus as the instructor pulls the release cord. (See figs. 26 to 29, incl.)



FIGURE 26.—Parachutist sliding down inclined beam of landing trainer. Instructor holds ropes tied to release mechanism.

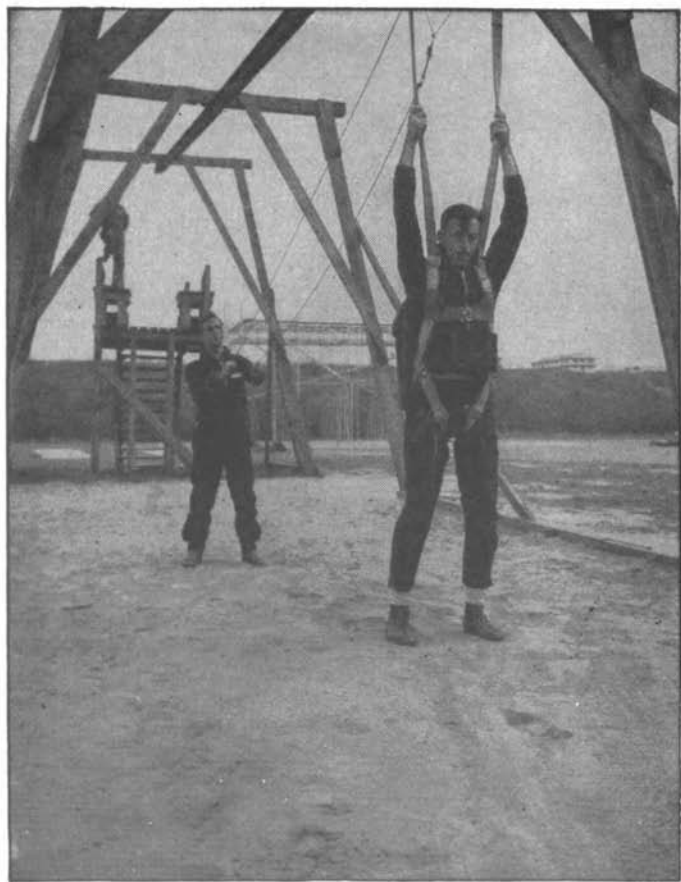

FIGURE 27.—Landing trainer. Student's feet touch ground momentarily at lowest position of inclined beam.



FIGURE 28.—Landing trainer. Instructor pulls release mechanism, allowing student to drop to ground.

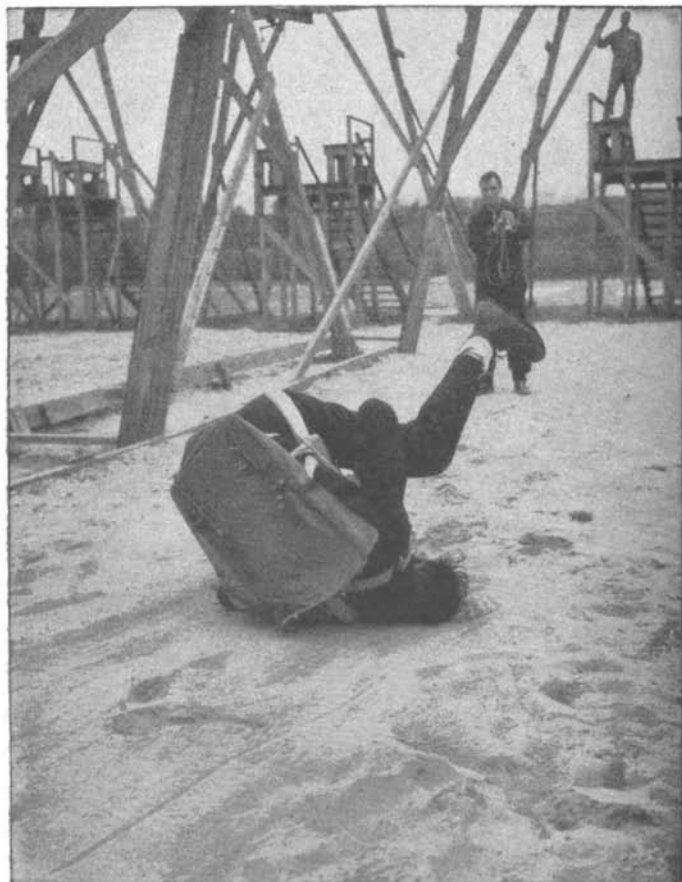

FIGURE 29.—Landing trainer. Upon being released from landing trainer, student executes a roll and recovery.

d. A jumping platform should be available for each 200 students. This is a platform with 2 outside levels each 5 feet above the ground and a center level 6 feet 10 inches above the ground. Steps should lead to both outside levels so that men may mount the platform from both sides. The jumping platform is used to develop the leg and ankle muscles, to accustom men to landing shock, and to teach them the principles of landing rolls. (See fig. 30.)



FIGURE 30.—Three- and five-foot jumping platforms.

e. A commercial type metal trainer or an improvised climbing trainer should be available for each 500 students. This apparatus is called a trainasium. The metal trainer is a structure 40 feet by 40 feet by 40 feet, made of metal stall bars. It has horizontal and vertical tunnels and inclined climbing ladders. It is used to develop the muscular coordination of the student and is an excellent substitute for mass calisthenics. (See figs. 31 and 32.)

f. Tumbling mats should be provided in the ratio of 1 for each 10 students, for use in tumbling practice and at jumping platforms and door mock-ups.

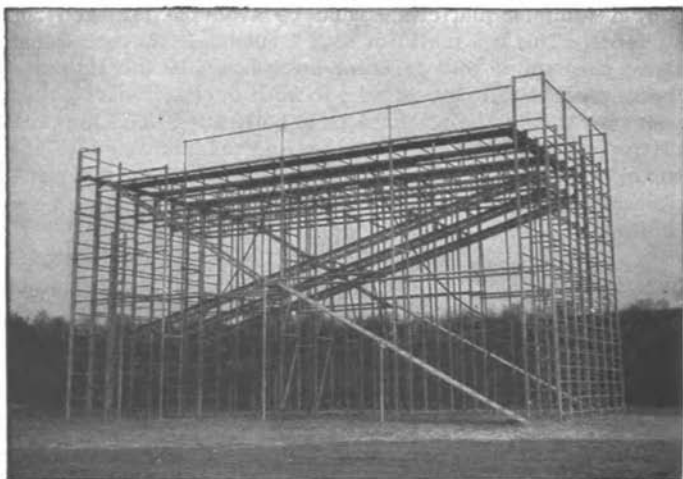

FIGURE 31.—Metal trainer or trainasium.

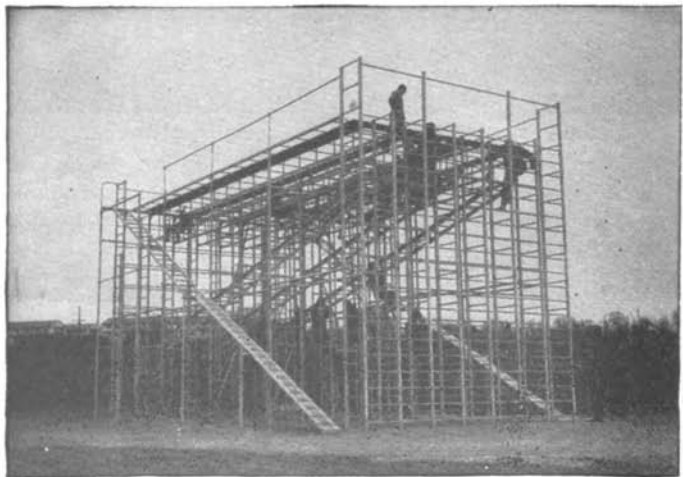

FIGURE 32.—Metal trainer in use.

g. The following items of equipment are very useful but not essential in jump training:

(1) Stall bars: 1 per 50 students.

(2) 1½-pound Indian clubs: 1 per 5 students.

(3) Trampoline type trainers: 1 per 150 students. The Trampoline trainer consists of a double-strength, heavy-duty canvas 6 feet 3 inches by 11 feet, stretched taut in an iron framework by means of metal springs to give a high degree of resiliency to the taut canvas. This enables the student to rebound from the canvas and practice body control exercises and flips in the air. (See fig. 33.)

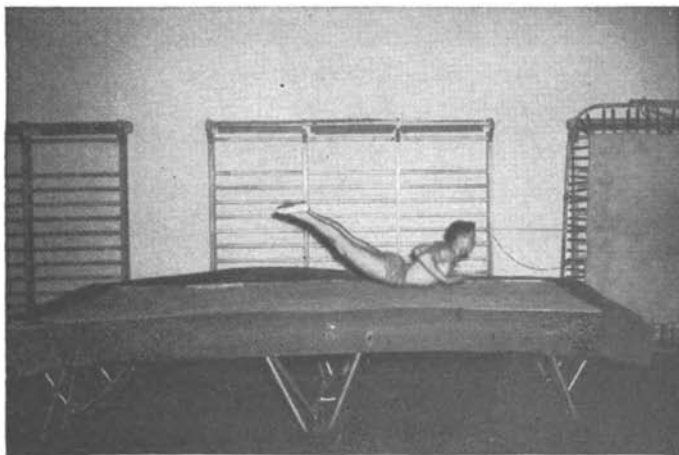

FIGURE 33.—Trampoline trainer.

(4) A windcharger machine, or an airplane motor with propeller, is desirable to create blasts of air that will inflate a parachute canopy and drag the student along the ground so that he may be taught to regain his feet in a high wind. (See figs. 34 to 37, incl.)

(5) Other training devices such as parallel bars, horizontal bars, rings, and weights which develop leg, shoulder, and arm muscles and teach body coordination may be included in the jump training equipment.

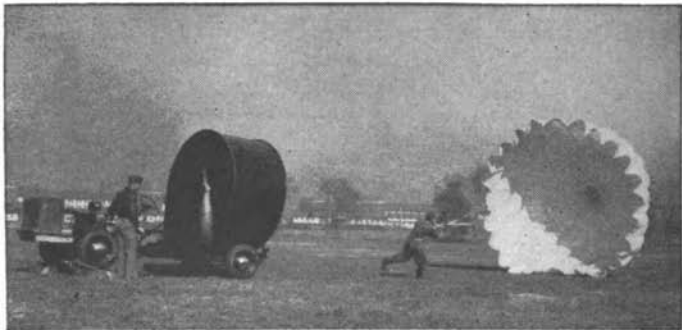

FIGURE 34.—With machine in use.

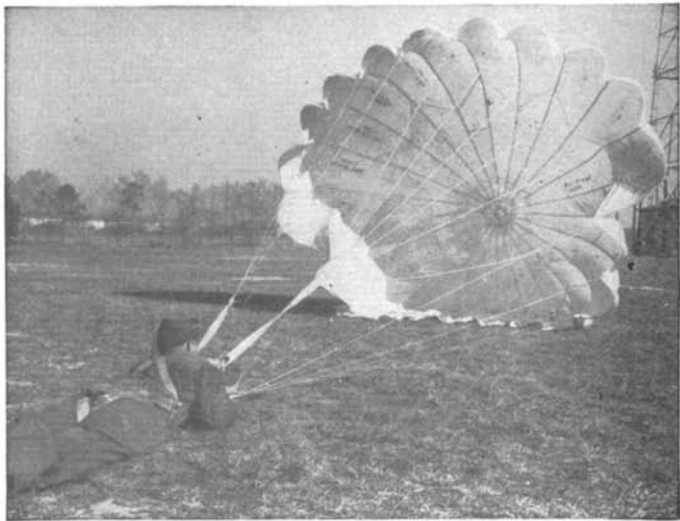

FIGURE 35.—Parachutist being dragged along ground by canopy inflated by wind machine.

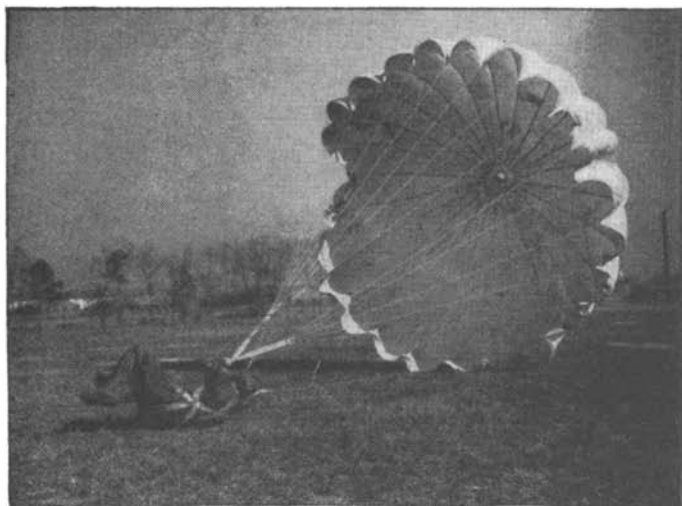

FIGURE 36.—Parachutist executing body roll preparatory to gaining his feet so that he can collapse his parachute.

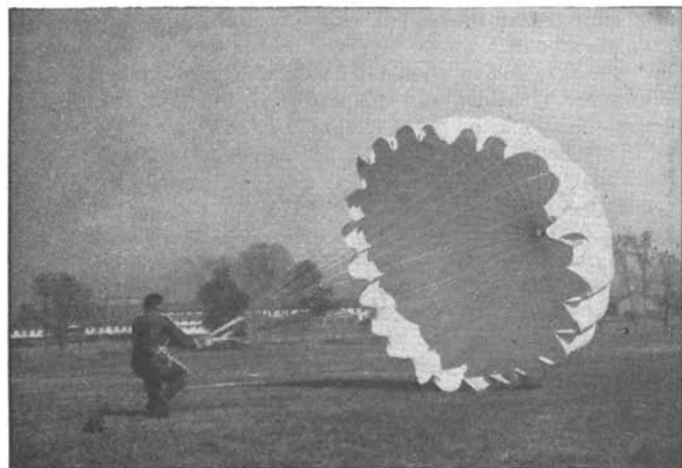

FIGURE 37.—Parachutist can now collapse his canopy by running into or around it.

■ 135. TOWER EQUIPMENT.—*a.* The following equipment should be available for operation at each control tower:

- 9 cotton canopies.
- 2 seat assemblies.
- 4 harness descent assemblies.
- 2 shock absorber harness assemblies.

For list of miscellaneous items of equipment necessary for controlled tower parachute operation, see Table of Basic Allowances No. 7-2.

b. The following equipment should be available at the free tower:

- 8 28-foot tower type parachutes.
- 8 32-foot tower type parachutes.
- 10 sets of attachable harness.

For list of miscellaneous items of equipment necessary for free tower parachute operation, see Table of Basic Allowances No. 7-2.

■ 136. MISCELLANEOUS EQUIPMENT.—*a.* Each instructor should be provided with appropriate summer and winter athletic uniforms. The summer uniform may consist of shorts, under-shirt, and athletic shoes. The winter uniform may be of a type similar to a basketball warm-up uniform.

b. Blackboards, movie projectors with screens, and projectors for film strips should be available for lecture periods. Whenever possible, still photographs illustrating jumping technique should be made available to the students for study and reference. A public address system is useful for giving mass instruction outdoors.

c. Equipment containers and delivery units at the ratio of 9 per 150 students should be available for the purpose of conducting equipment drill or instruction in methods of loading and ejecting delivery units. Dummy parachute packs should be provided for use at door mock-ups at the rate of 24 per door mock-up. One complete condemned parachute assembly should be available per each 20 students for the purpose of teaching the collapsing and collecting of parachutes.

SECTION IV

PACKING COURSE

■ 137. GENERAL.—*a.* The course in parachute packing is designed to teach the student all operations involved in packing, caring for, and inspecting his own parachute. This course should be given concurrently with the jumping course and must be successfully completed before the student proceeds to the qualifying jumping phase of parachute training.

b. During the periods in which he makes his qualifying jumps, each man repacks his parachute under supervision of an instructor for each successive jump. Packing training is conducted in the packing building.

■ 138. EQUIPMENT AND PERSONNEL.—The equipment necessary for each packing table is listed in paragraph 133. If practicable, the number of students assigned to each table should be limited to two. Three students to each table should be the maximum. An instructor should be assigned for each six tables, and have a maximum of 18 students under his direct supervision. The instructor should grade each student daily on his practical work and recitation of text assignments. An officer supervisor should be available for each 250 students. Each student should be provided with a student's text to be used in connection with the course. This text should contain an explanation of the nomenclature and operation of a complete parachute assembly. In addition, each instructor should be provided within an instructor's text which explains the daily instructional procedure.

■ 139. OUTLINE OF COURSE.—*a.* The following allotment of hours devoted to packing procedure for the troop type parachute is suggested:

	<i>Hours</i>
Lecture on purpose, and method of conducting the course.....	1
Care of equipment.....	1
Nomenclature and functioning of parachute.....	2
Laying out of parachute.....	1
Removal of twists and tangles in suspension lines.....	3

	<i>Hours</i>
Inspection of parachute.....	2
Panel folding, right-hand group of panels.....	3
Panel folding, left-hand group of panels.....	3
Complete folding of canopy.....	4
Stowing of suspension line in pack.....	5
Closing and sewing of pack, to include necessary tacking.....	2
Complete packing of back pack.....	5
Lay-out of reserve parachute.....	1
Complete packing of reserve parachute.....	3
Harness adjustment.....	3
Records and forms.....	1
Hanging and checking of parachute for drying.....	1
Collecting parachutes and bin storage.....	1
Field folding.....	2
Written examination.....	2
Practical examination, to include complete packing of troop type parachute, main and reserve..	6

b. Schedules should be arranged so as to include the items of instruction in the order listed above. Constant reference must be made to the student's text. Instructors should re-assign their students so as to have slow and fast students work at the same table.

■ 140. QUALIFICATION.—Students are considered qualified who—

a. Attain a grade of 75 percent or better on a written test of 50 questions covering the nomenclature, construction, design, and functioning of the troop type parachute.

b. Under supervision of an instructor, completely pack, without assistance, a troop type parachute so as to insure its proper functioning in a live jump or drop test.

c. Attain passing grades on daily practical work and recitation.

■ 141. MISCELLANEOUS.—a. The following regulations should be enforced in the packing course:

(1) No smoking will be permitted in the packing room at any time.

(2) A 10-minute break will be given at the end of each 50 minutes of instruction.

(3) No student will be excused from class without permission of the officer or instructor in charge.

(4) No student will sit on packing tables except when he is folding panels or when specifically instructed to do so by proper authority.

(5) Students will wear the prescribed uniform.

(6) Students will police the packing room under supervision of the instructors.

(7) Students will be held responsible for care of the equipment they use.

(8) During the 10-minute breaks students will leave the tables, but will remain in the immediate vicinity of the packing building.

b. Students showing obvious inaptitude in the mechanics of folding and packing, or in understanding parachute instruction, should be relieved at the earliest opportunity.

c. During open periods, tables should be available to slow students, or students who have missed previous lessons, so that they may keep up with current instruction.

d. For packing procedure for the troop type parachute, see TM 1-440.

SECTION V

JUMP TRAINING COURSE

■ 142. GENERAL.—The purpose of the jump training course is to produce trainees who are capable of—

a. Withstanding the physical shocks that are encountered in parachute landings.

b. Jumping from a plane without hesitation and without danger to fellow jumpers.

c. Manipulating the parachute during descent so as to land in a suitable area.

d. Landing without injury.

■ 143. EQUIPMENT AND PERSONNEL.—a. For a description of the equipment referred to in subsequent paragraphs, see paragraph 134.

b. During jump training, students should work in groups of 50 or less. There should be at least 2 enlisted instructors for each 50 men, and an officer supervisor for each 150 men. Daily records should be kept by instructors of each student's progress or lack of ability in the various phases of training.

■ 144. **OUTLINE OF COURSE.**—*a.* The following allotment of time to the various phases of the jump training course together with an outline of the instruction to be covered in each phase is suggested:

	<i>Hours</i>
Suspended harness-----	6
To include slipping or guiding the parachute in descent, checking oscillation, landing attitude, water landings, tree landings, wire landings, and performance data.	
Door practice-----	6
To include the technique of individual and mass exits, practice in mass jumping, and demonstration of jumping errors.	
Landing trainer-----	6
To include the technique of landing with a forward momentum, and the execution of body turns with landings.	
Tumbling and platform-----	6
To include forward and rear tumbles, zig-zag tumbling, obstacle tumbling, and platform jumps with accompanying rolls.	
Trampoline and stall bars-----	6
To include basic coordination and body control exercises on the trampoline, and arm, leg, and abdominal exercises on the stall bars.	
Trainasium-----	10
To include climbing on stall bars, weaving through tunnels and tower wall, rope climbing, platform and bar jumps, and ramp and catwalk walking.	
Lectures-----	4
To include preliminary familiarization lecture at beginning of course, and films and lecture on jumping technique at the end of the course.	

Qualification tests..... 8

To include a written test on performance data and practical tests on the apparatus.

b. Particular care must be taken in the arrangement of daily schedules to insure that the physical exercises given consecutively during the course do not overtax the student. For example, trainasium exercises should be followed by suspended harness or door practice, rather than by tumbling and platform, or by trampoline and stall bars.

■ 145. **QUALIFICATION.**—The following should be considered as the standard for qualification in the jump training course:

a. A grade of 75 per cent or better in the written test on performance data.

b. An average grade of 75 per cent or better in practical tests on the various apparatus.

■ 146. **MISCELLANEOUS.**—*a.* Salt tablets should be available to students during periods of excessive heat. During winter months, except in extremely cold climates, the training building should remain unheated so that students moving in and out of the building will not suffer from excessive changes in temperature.

b. Backward or uncoordinated students may be given extra instruction provided it does not interfere seriously with their progress in daily instruction. All students should be encouraged to do extra work on their own initiative during free periods. With this end in view the training building should be kept open after duty hours.

c. A medical officer should be present at the training building or readily available during training periods.

d. Men who receive injuries that prevent training for a period of 3 or more days should be turned back to the next class. No man should be permitted to jump or take jump training following an injury until he has been examined and authorized to do so by a medical officer.

SECTION VI

TOWER TRAINING COURSE

■ 147. **GENERAL.**—The purpose of the tower training course is to produce trainees who have demonstrated an ability to make

live parachute jumps, to teach the technique of collapsing the parachute in the wind, and to eliminate those students who demonstrate adverse physiological reactions or inaptitude for parachute jumping.

■ 148. **EQUIPMENT AND PERSONNEL.**—*a.* The towers are of two types: a controlled tower, on which the ascent and descent of the canopy is controlled by guide cables; and a free tower from which the parachute is permitted to make a free descent upon being released at the top of the tower. All arms of both towers operate on the same principle: the parachute is carried to the top of the tower by means of a cable, the parachute being secured to the cable by means of a spring release; at the top of the tower the spring release is compressed and the parachute is free to descend. For the purpose of teaching how to collapse and collect the parachute in a high wind, an old airplane motor with propeller, or a windcharger may be used to create the wind velocities needed. (See fig. 34.)

b. A minimum of two instructors should be available on each arm of the controlled tower, and one instructor on each arm of the free tower. Twelve instructors can conduct all phases of instruction.

c. Records must be kept on each phase of the tower training to insure that each student completes the successive steps on the controlled tower before progressing to the free tower.

■ 149. **OUTLINE OF COURSE.**—The following allotment of time and training sequence is suggested.

	<i>Hours</i>
<i>First day</i> -----	
Seat descents-----	2
Rigging drill (free tower)-----	1
Collecting parachutes-----	1
<i>Second day</i> ---	
Seat descents-----	1
Harness descents-----	1
Rigging drill (free tower)-----	1
Collecting parachutes-----	1
<i>Third day</i> ---	
Harness descents-----	1
Shock absorber harness-----	1
Rigging drill (free tower)-----	1
Collapsing parachute (run around)-----	1

	<i>Hours</i>
<i>Fourth day</i> --- Harness descents-----	1
Shock absorber harness-----	1
Free descents (forward)-----	2
<i>Fifth day</i> --- Harness descents-----	1
Collapsing parachutes (bottom lines)-----	1
Free descents (check oscillation)-----	2
<i>Sixth day</i> --- Collapsing parachutes (assistance)-----	1
Recovery from drag-----	1
Free descents (slipping)-----	2
<i>Seventh day</i> --- Collapsing parachutes (review)-----	1
Recovery from drag-----	1
Free descents (body turns)-----	2
<i>Eighth day</i> --- Collapsing and collecting parachutes (review)-----	1
Recovery from drag-----	1
Free descents (body turns)-----	2
<i>Ninth day</i> --- Test—free descents-----	2
Test—collapsing and collecting para- chutes-----	2
Total -----	36

■ 150. QUALIFICATION.—*a.* A student should be considered qualified in the tower training course when he has—

- (1) Made two correct landings from the free tower.
- (2) Demonstrated proficiency in collecting his parachute on the field.
- (3) Demonstrated proficiency in collapsing his parachute in the wind.
- (4) Demonstrated proficiency in recovering from the drag position.

b. A student should be disqualified in the tower training course for—

- (1) Refusal to go aloft on any phase of the tower training.
- (2) Continued execution of incorrect landing technique.
- (3) Inability to collapse his parachute.

■ 151. MISCELLANEOUS.—*a.* Jumping boots, if available, should be worn for all tower descents.

b. Students should not be permitted to loiter in the vicinity of any of the landing aprons on the controlled tower while it is in operation.

c. No student should be required to make more than three free descents in any one training period.

d. A medical officer should remain on duty at the towers during training periods.

e. The free towers should not be used when the ground wind is in excess of 15 miles per hour. When such winds deny the use of the free tower, other training should be given to the class at the tower area. Every effort should be made to give each student a minimum of eight practice descents from the free tower. Repetition of harness descents on the controlled tower vastly improves the landing perspective of the student.

f. In giving instructions to students while they are descending from the free tower, the instructor must bear in mind that the brief time of descent does not permit execution of more than three separate maneuvers of the parachute by the student. He must also allow ample time for the execution of any ordered maneuver. Commands given loudly and in rapid succession are not only impossible of execution, but cause the descending student to become excited. Particular care must be taken to insure that no instructions are given which would require a change in the student's body position after he is within 50 feet of the ground. The student must be informed of his errors immediately after landing.

SECTION VII

QUALIFICATION JUMPING

■ 152. GENERAL.—a. After the student has successfully completed all the preliminary training in packing, working on apparatus, and tower jumping, he is permitted to make his qualifying jumps from an airplane in flight.

b. The purpose of the jumps is to acquaint the student with the psychological factors involved, and to reduce mental hazard to a minimum. The actual jump does much to alleviate nervous fears or doubts concerning the parachute. There are two major considerations that concern the jumper:

first, that he can effect a safe landing by proper manipulation of the parachute during descent and by proper landing technique; and second, that his exit from the plane is certain, rapid, and correct, so that he is not a danger to others.

c. To qualify for rating as "Parachutist" the student should be required to make 5 satisfactory jumps from varying altitudes in at least 2 of which he participates in mass jumps of 12 men each. Performance records must be kept on each student during the qualifying jumps. The student must repack his own parachute.

■ 153. EQUIPMENT AND PERSONNEL.—a. A flat, smooth field 2,000 yards by 1,000 yards, free from obstructions, should be available for novice, or student jumping. A larger field is desirable. If possible, the field should be at least 2,000 feet from large bodies of water. High woods or hills cause turbulent conditions of surface wind. Therefore, whenever choice permits, the field should be free from such natural wind obstructions. Attention should be paid to the direction of normal prevailing winds of the locality so that, if possible, the longer axis of the field may extend in that direction. Also consideration should be given to the nearness of the field to the packing buildings, in order that a minimum of time will be lost in transit to and from the field. Trees or heavy brush should be either uprooted or left standing. Stumps are greater hazards to the jumper than are trees. Burrs, brush, insects, etc., cause great damage to the silk canopy of the parachute; therefore, facilities and men must be provided to maintain the field.

b. It is desirable to conduct the qualification jumping on successive days. The number of transport planes needed should be determined on the basis of 1 plane for each 100 students. In order to provide for continuity of training, a spare plane should be provided for each five transport planes. All planes used must be prepared for use in jump training and must be inspected in accordance with the jumpmaster's inspection check list before they go aloft.

c. The following equipment should be available to the ground crew for novice jumping:

(1) Two red panels, and two white panels, each of cloth and 10 feet by 5 feet.

(2) Six red cloth flags each 2 feet square.

(3) One pair of binoculars for each ground instructor and one for the officer in charge of the jumping field.

(4) One wind anemometer.

(5) Clip boards, pencils, and rating forms for each ground instructor.

(6) One truck, 2½-ton, for each two transport planes used. These trucks are to carry personnel from the jumping field.

(7) One ambulance with medical supplies.

d. The normal complement of the ground crew should include—

(1) One officer in charge, to direct jumping and control panels and crews.

(2) One ground instructor for each plane used, to grade the performance of the student jumpers.

(3) A minimum of three injury flagmen, to signal the ambulance to proceed to injured jumpers.

(4) One noncommissioned officer, to take wind readings at regular intervals.

(5) Three panel men, to lay out and move the panels.

(6) One dispatcher, to load and control movements of personnel trucks on the jumping field.

(7) Medical personnel to accompany the ambulance.

e. When the ground is wet a crew of not less than 12 men should be available on the field to assist in the collecting of parachutes to prevent their getting too damp.

■ 154. JUMPING PROCEDURE.—a. *Procedure at packing building.*—(1) Individual parachutes are kept in individual bins assigned each student. These bins are marked so that they are easily identified by the students. No equipment other than parachutes, kit bags, and helmets should be permitted in these bins.

(2) Students are assigned to jumpmasters in groups of 12 on a "Jumpmaster's Record Form." Upon reporting at the packing building these groups are marched as units to the bin rooms and secure parachutes. The men then proceed to a packing table and, working in pairs, put on their para-

chutes. Each group is then inspected by competent riggers, or officers, in accordance with the "Jumpmaster's Inspection Check List."

(3) When all men in a group have been inspected, the officer in charge of the building assigns them to a plane. They are marched as a unit and reported to a noncommissioned dispatcher who insures that they report to the correct plane.

(4) After the students have completed their jumps they are carried by truck from the jumping field to the packing building, where they sign their parachute forms indicating thereby that their parachute has received a live jump. A rigger records the jumper's name and the number of each parachute so jumped. The students then report to the shake-out room where their parachutes are shaken out, and a rigger inspector determines whether or not the parachutes must receive drying. Students are then directed either to hang their parachutes for drying, or store them in their bins to await repacking, or they are assigned to tables with their inspection cards to repack their parachutes. Upon completion of packing, the parachutes are restored to their proper bins.

b. Procedure on planes.—Each transport plane carries a qualified jumpmaster whose duty it is to jump and grade the students. The jumpmaster inspects the students in accordance with his check list and then has them enplane. After the take-off, the jumpmaster is responsible that the correct altitude is reached, the correct course is flown, and that the students are jumped at the correct point along the course. As the plane approaches the jump-off point along the course, the jumpmaster causes the student to stand up and hook up. He then makes the required inspection of the jumper and has him take position in the door. As the jump-off point is reached, the jumpmaster gives the signal to "Go". The student is graded by the jumpmaster on his flight reaction, command reaction, and exit; this data is later transferred to the student's "Jump Record Card." Static lines are recovered from the exterior of the plane by the jumpmaster after each individual or group jumps, and after landing are turned over to the packing building crew.

c. Duties of ground crew.—(1) The officer in charge of the ground crew obtains data as to wind conditions both aground and aloft from the weather station. From these data he determines a flight course for the planes, which he plots on an aerial photograph of the jumping ground. This course is indicated to the assembled pilots and jumpmasters on an aerial photograph and by naming prominent landmarks for used as navigation aides.

(2) A jump-off point is a point along the line of flight over which the jumpmaster is to cause the men to jump. It is designated on the ground by means of two red panels displayed to the left of, and on a line perpendicular to, the line of flight, the nearer panel being at least 50 yards and the other at least 150 yards from the line of flight. The point where the line so designated crosses the line of flight is the jump-off point. Based upon existing wind conditions, an initial point is selected which, it is estimated, will cause jumpers to land in the desired area.

(3) The jumpmaster of the leading plane is provided with a wind dummy which he drops over the selected jump-off point on the first trip over the field. If this dummy does not land in the desired area the red panels are moved so as to designate a jump-off point which will correct for the error.

(4) White panels, displayed near the center of the jumping area, are used by the officer in charge of the ground crew to control jumping. To indicate to jumpmasters that personnel may be jumped, two white panels are displayed parallel to each other and separated by about 10 feet. In order to cancel all jumping and order all planes to land, the two white panels are displayed crossed. The absence of either of these signals indicates to jumpmasters and pilots that wind dummies or equipment may be dropped but no personnel is to jump.

(5) As jumping proceeds the officer in charge causes any necessary changes to be made in the panels and checks wind readings taken on the field. When the surface wind exceeds 10 miles per hour he causes cessation of jumping until the wind decreases. Ground instructors are assigned to observe individual planes. As each jumper leaves the plane he is

graded on his performance, and is assigned a number in accordance with his order of jumping from the plane. The ground instructor's rating form is later attached to the corresponding jumpmaster's form so as to make a complete record of each jump. Injury men with red flags observe the landing of each jumper and, in event of an injury, immediately wave their flags and run to the assistance of the injured man. The ambulance follows the flag. The panel men stand by the white panels and, upon signal from the officer in charge make necessary panel changes. The dispatcher controls movements of personnel trucks on the field and assigns students to trucks after they have landed for return to the packing building. Each student is required to collect his parachute after landing. Kit bags should be provided to carry the parachutes back to the packing building. Care must be taken during mass jumping to keep the field cleared of trucks and to keep the landed jumpers on the alert for descending jumpers.

■ 155. JUMPING REGULATIONS.—The following regulations should govern student jumping operations:

a. Jumps should not be made in surface winds exceeding 10 miles per hour.

b. Large bodies of water within 2,000 feet of the jumping field should be patrolled by boats during jumping.

c. Injured men should be moved only by medical personnel. Members of the ground crew may effect loosening or removal of the harness of injured men, if such action does not require excessive movement of the patient.

d. Students should not be kept aloft for periods in excess of 1 hour awaiting suitable wind conditions.

e. No unauthorized personnel should be permitted on the jumping field while jumping is in progress.

f. In event of a serious or fatal casualty, all men except the medical officer and necessary assistants should be kept away from the scene of the accident.

g. All injuries to personnel or malfunctions of parachutes will be reported in writing to his immediate commanding officer by the officer in charge of the jumping field.

■ 156. **DISQUALIFICATION.**—A student shall be considered as disqualified during his training for any of the following reasons:

- a. One refusal to go aloft for a scheduled jump.
- b. One refusal to jump from the plane in flight.
- c. Tendency toward airsickness, hysteria, or extreme nervous condition prior to the jump.
- d. Use of liquor, drugs, or any other artificial nerve sedative.
- e. Continued hesitancy, or weak exits from the plane.
- f. Repetition of erroneous jumping technique on successive jumps.
- g. Failure to observe the prescribed rules of packing and jumping.

■ 157. **MISCELLANEOUS.**—Only determined and sure jumpers are suitable for the parachute service. Therefore, it is imperative that instructors or jumpmasters do not attempt to push a jumper from the plane nor by means of threats or cajolery cause him to jump. Although it is perfectly proper to attempt to relieve the natural nervous stress of the novice jumper by cheerful conversation or encouraging remarks prior to the jump, no moral or physical pressure should be brought to bear on the student in order to have him jump. The weak or doubtful jumper is capable of refusal at any time; therefore, little is gained by qualifying a man who may later refuse to jump. No man should be permitted more than one failure to jump. If a man fails to jump on a given passage over the jumping field and claims not to have heard the command of the jumpmaster, this fact should be recorded on the grade form so that the hesitancy may be verified on subsequent jumps. All preliminary training points to the jump; therefore the instructor should not hesitate to disqualify men after they have jumped once or twice, if their demonstrated technique shows that they are potential jump casualties. When the student's record shows that he has committed certain errors, these errors should be called to his attention so that he may correct them. The initial jump constitutes such an emotional stimulus for the average man that excellent performance is not to be expected. However, progressive proficiency should be shown in subsequent jumps.

SECTION VIII

EQUIPMENT DRILLS AND ADDITIONAL TRAINING

■ 158. **EQUIPMENT DRILL.**—The purpose of equipment drill is to acquaint the student with methods of loading, ejecting, and securing the delivery units of the tactical organizations. The course consists of three periods, each of 4 hours duration, and should cover the following items:

a. First period.—(1) Demonstration of the packing of equipment in delivery unit containers.

(2) Practice packing of delivery unit containers by the students.

(3) Instruction in the method of identifying delivery units and in securing proper equipment from the delivery units.

(4) Practice in securing equipment from delivery units by the students.

b. Second period.—(1) Method of attaching a parachute to the delivery unit container.

(2) Method of attaching delivery units to the plane.

(3) Method of ejecting delivery units from the plane.

(4) Practice loading and ejection of delivery units by the students.

c. Third period.—(1) Students start from a simulated landing pattern on the ground and secure equipment against time.

(2) Students completely pack, load, drop, assemble on, and secure equipment from delivery units as for a tactical exercise.

■ 159. **LECTURES.**—The following subjects are covered:

a. Lecture No. 1.—History of the parachute from the Da Vinci conception to the present day parachute; the relation between development of the parachute and the airplane; early World War I parachutes of the fixed station type, and the introduction of the free type parachute; need for a free type parachute for the pilot; some of the various designs for parachute canopies and operational features; safety features of the parachute. The lecture should be concluded with pictures showing operation of some of the earlier type parachutes and training films on the modern parachute.

b. Lecture No. 2.—History of the principle of vertical envelopment and parachute troops; early mass drops at Chanute Field; acceptance of the idea by Russia and Germany, and development of parachute troops in those countries; review of some of the successes with personnel, weapons, and equipment. The lecture should be concluded with the showing of a training film on foreign parachute troops.

SECTION IX

SPECIALIST SCHOOLS

■ 160. **GENERAL.**—Every parachute unit requires trained jumpmasters and specialists in demolitions, rigging, and parachute communications. Specialist schools may be organized to train personnel in these subjects.

■ 161. **DEMOLITIONS SCHOOL.**—*a. Purpose.*—The purpose of a demolitions school is to train men in the handling and employment of explosives, so that they may effectively accomplish demolition missions of all types.

b. Instructors.—The officer in charge of the school should have such commissioned officer assistants as are necessary. Noncommissioned officers, experienced or previously trained in demolitions work, act as assistant instructors, one in charge of each instructional group (one squad).

c. Students.—Students selected for this training should be qualified parachutists with particular aptitude or previous experience.

d. Scope.—The course should be designed to instruct parachute troops in *practical* employment of the various types of explosives. Extensive instruction should be given in the handling, care, and tactical use of military explosives. The student should be given an opportunity to handle explosives during supervised practical work. When the class has acquired skill in handling explosives, calculating charges by use of formulas, and tamping and placing charges, tactical walks should be conducted. These walks should take the men through filter plants, radio stations, telephone exchanges, heating plants, and other utility works. The class should be guided through the works by a plant expert and vulnerable

features of the plant should be pointed out. Since demolition missions will frequently require employment of motorcycles, trucks, locomotives, tanks, and other military vehicles, training should be given in their operation.

e. Outline of course.—The following allotment of time for a 2-week demolitions course is suggested:

	<i>Hours</i>
Explosives: types, characteristics, and employment.....	8
Electrical demolitions: practical types and employment.....	8
Structural demolitions: formulas and practical work.....	8
Antitank methods: traps, obstacles, grenades, etc.....	8
Locomotives: driving and tactical walk through roundhouse....	4
Utilities: tactical walk through radio station, telephone exchange, etc.; practical work with grenades.....	8
Bridges, aqueducts: tactical walk through water filtration plant.....	8
Airfield: destruction of aircraft on the ground, and gas motors; ignition instruction.....	8
Trucks, motorcycles, and tanks: driving instruction; demolition of tanks.....	8
Problems, live tactical jump to include demolition mission....	8
Critique of course and graded test.....	4
Total	88

■ 162. PARACHUTE RIGGERS' SCHOOL.—*a. Purpose.*—(1) The purpose of the parachute riggers' course is to train officers and men in the following: construction principles, maintenance, repair, and inspection of parachutes and auxiliary equipment; operation, repair and maintenance of shop, packing building, and special equipment; duties of a parachute specialist (maintenance); use of all types of parachutes (seat, back, quick release, quick attachable, flare and delivery units).

(2) Students should be selected from those who have shown exceptional ability in the packing course.

(3) The suggested course consists of four phases of training of 44 hours each. Each phase is divided into five periods of 8 hours each and one period of 4 hours.

b. School building.—A school building or section of a packing building should be divided into four "stage" rooms. Stage "A" should have adequate floor space to accommodate five or more packing tables with drying facilities for parachutes. Stage "B" should have a large, well lighted room, equipped for basic instruction in sewing on standard sewing machines. Stage "C" should have a well lighted room equipped for in-

struction in sewing on heavier sewing machines and for instruction in hardware. Stage "D" should have a room equipped with the tools and other equipment necessary to accomplish repairs and maintenance work of the type handled by a parachute rigger or by a maintenance section.

c. School staff.—The school staff should consist of 1 officer director assisted by 1 noncommissioned officer supervisor and 8 instructors for each 40 students.

d. Outline of course.—The following allotment of time for a 4-week parachute riggers' course is suggested:

Subject	Hours				
	Total	1st week	2d week	3d week	4th week
Lectures	10	3	2	2	3
Advanced parachute packing	30	30			
Demonstrations, air corps parachutes	8	2	2	2	2
Hand sewing, packs	2	2			
Hand sewing, harness	2	2			
Harness adjustment	1	1			
Machine sewing, harness	15			15	
Machine sewing, silks and cloth	30		30		
Machine shop work	15			15	
Flotation equipment	2				2
Canopy repair	7		4		3
Battalion supply procedure	6				6
Shop orders	12				12
Clothing repair	8			4	4
Seam and stitching application	10				10
Blue print reading	6	2		4	
Machine repair and adjustment	4		4		
Examinations	8	2	2	2	2
Total	176	44	44	44	44

■ 163. PARACHUTE COMMUNICATION SCHOOL.—*a. Purpose.*—The purpose of the parachute communication school is to train personnel in communication technique peculiar to parachute combat.

b. Organization of school.—A communication officer should be placed in charge of the school and provided with capable assistant instructors.

c. Students.—Students should be selected from qualified parachutists who have a satisfactory code aptitude rating.

d. Outline of course.—The schedule shown below is intended for use as a guide only. It is considered suitable for training students who have completed basic communication training.

	<i>Hours</i>
Organization of parachute units; means of communication.....	2
Employment of personnel and equipment.....	2
Orders and signal operation instructions.....	2
Parachute delivery units.....	2
Code practice.....	58
Wire and telephones.....	2
Visual signaling.....	2
Panels.....	10
Message center procedure.....	4
Messages, oral and written.....	4
Radio sets.....	13
Field nets.....	43
Pyrotechnics.....	2
Command post installation and operation.....	10
Air Force communication methods, radios, etc.....	4
Field exercises.....	16
Total	176

■ 164. JUMPMASTERS' SCHOOL.—*a. General.*—Jumpmaster training should be given to all officers, noncommissioned officers, and prospective noncommissioned officers.

b. Purpose.—(1) The purpose of this course is to produce jumpmasters capable of supervising the enplaning and jumping of personnel and equipment.

(2) The course should train each student—

(a) To inspect personnel, planes, and equipment, prior to take-off for jumping.

(b) In the technique of command for mass jumping and release of equipment in various plane formations.

(c) In the recognition of terrain from the air by reference

to aerial photographs and maps, time of flight, and distance estimation.

(d) In the technique of releasing jumpers and equipment so as to compensate for wind drift.

c. Outline of course.—(1) *First day (4 hours).*—Method of inspecting jumper's parachutes and equipment and the plane attachments, using jumpmaster's inspection form; various ways of preparing delivery units for release, and inspection of attachments to plane; practical work on the ground in commands for enplaning and jumping, to insure proper procedure and timing; release of individual equipment and "daisy-chain" delivery units.

(2) *Second day (4 hours).*—Attachment and release of equipment using bomb bays and blister attachments; map and aerial photograph study of a triangular course of 150 miles; recognition of terrain and timing flight over successive points; flight along a triangular course with each student keeping a flight log and map course.

(3) *Third day (4 hours).*—Study of time, distance, and wind drift tables; means of estimating wind drift and ground distance covered during timed flight; flight over known distance markers to enable students to estimate ground distance from various altitudes.

(4) *Fourth day (4 hours).*—Methods of sighting from plane to determine course landing patterns expected in mass jumps from various altitudes; flight with dummy dropping to simulate mass jumps; spot dropping of dummies on ground markers.

INDEX

NOTE.—Numbers in *italics* refer to air landing troops.

	Paragraph	Page
Action:		
Enroute.....	23, 105	19, 77
On ground.....	24, 106	19, 77
Prior to enplaning.....	104	77
Action after landing.....	28	24
Advice to instructors.....	124-164	87
Aid stations.....	19, 86	18, 80
Air alert.....	2	1
Air landing troops.....	1-38	1
Definition.....	2	1
Air superiority.....	4	2
Air task force, definition.....	2	1
Air transport movement table.....	24	19
Air-borne troops, definition.....	2	1
Airfields:		
Departure.....	17, 23, 24	12, 19
Operations to seize.....	107	77
Altitude of flight.....	99	73
Ammunition.....	16, 22, 35, 54, 89	12, 17, 29, 51, 68
Areas, landing.....	44, 92, 93, 153	34, 70, 119
Armament:		
Air landing troops.....	5	3
Parachute troops:		
Battalion.....	75	58
81-mm mortar platoon.....	65	56
Rifle company.....	69, 70	56, 57
Rifle squad.....	50	50
60-mm mortar squad.....	61	53
.30 cal. machine-gun platoon.....	67	56
Arrival at departure airport and loading:		
General.....	26	22
Officers in charge.....	26, 104	22, 77
Assembly after landing.....	28, 53, 59, 62	24, 51 53, 55
Assembly points.....	28, 53, 59, 62	24, 51 53, 55
Attack:		
Beyond initial objectives.....	30	26
To contact troops landing in adjacent areas.....	30	26
To destroy enemy reserves.....	30	26
To destroy hostile artillery.....	30	26
To separate enemy forces.....	30	26
For initial objectives.....	29	26

TACTICS AND TECHNIQUE OF AIR-BORNE TROOPS

	Paragraph	Page
Aviation.....	2, 7, 8, 20	1, 4, 14
Supporting:		
Communication with.....	20, 116, 119-122	14, 82, 85
Missions of.....	7, 8, 119-121	4, 85
Rehearsals.....	103	76
Transport:		
Characteristics of.....	47, 120	47, 85
Use of bombardment for.....	47	48
Battalion, parachute.....	74-76	58
Composition.....	74	58
Supply and jumping technique.....	76	58
Tactical employment.....	42, 92	32, 70
Bomb safety line.....	2	1
Characteristics of air landing troops:		
Mobility:		
In the air.....	4	2
On the ground.....	4	2
Tactical operations.....	27	24
Vulnerability.....	4	2
Civilians, treatment, in occupied territory.....	18, 37, 38	13, 30
Codes.....	20	14
Combat aviation.....	4, 7, 8, 20, 116, 119-121	2, 4, 14, 82, 85
Command posts.....	20, 113	14, 81
Commanders and staffs.....	6	3
Employment of.....	20, 34, 107	14, 28, 77
Equipment.....	115, 118	81, 84
General.....	20, 108	14, 80
Hostile.....	20, 117	14, 84
Officers.....	20, 34, 112	14, 28, 81
Means.....	20, 34, 114	14, 28, 81
Messengers.....	20, 34, 116	14, 28, 82
Organization.....	108, 111	80, 81
Panels, with combat aircraft.....	20, 34	14, 28
Parachute units.....	107, 108-118	77, 80
Pigeons.....	20, 34, 116	14, 28, 82
Pyrotechnics.....	20, 34	14, 28
Radio.....	20, 34, 116	14, 28, 82
School.....	163	128
Tactical employment.....	20, 34, 116	14, 28, 82
Telephone.....	20, 34	14, 28
Company:		
Parachute.....	69-73	56
Rifle:		
Composition.....	69	56
Missions.....	71	57
Composition:		
Air landing troops.....	5, 27	3, 24
Parachute troops:		
Battalion.....	74, 88	58, 68
81-mm mortar platoon.....	65	56
Group.....	88	68
Machine gun platoon.....	67	56
Regiment.....	77, 88	58, 68

BASIC FIELD MANUAL

Composition—Continued.		Paragraph	Page
Parachute troops—Continued.			
Rifle company.....	69	56	
Rifle platoon.....	63	55	
Rifle squad.....	49	50	
60-mm mortar squad.....	60	53	
Communication.....	20, 34	14, 28	
Air-ground voice radio.....	20, 34	14, 28	
Between air landing troops and supporting aviation.....	20, 34, 116	14, 28, 82	
Between air landing units and other ground elements.....	20, 34, 116	14, 28, 82	
Codes.....	20	14	
Conduct of personnel.....	38	30	
Conferences:			
Air landing troops.....	21	17	
Pilot—jumpmasters.....	101	75	
Jumpmaster—unit commander.....	102	76	
Contents of orders.....	10, 22, 25	9, 17, 20	
Control.....	20, 28, 92	14, 24, 70	
Counterattacks, precautions against.....	31-33	27	
Defense.....	33	28	
Definitions:			
General.....	2	1	
Jumpmasters.....	85	63	
Parachute troops.....	40	31	
Delivery units:			
Definition.....	46	38	
Description.....	46	38	
Drill.....	84, 158	62, 125	
Dropping.....	46	38	
Marking.....	46	38	
Packing.....	46	38	
Types.....	46	38	
Demolition school.....	161	126	
Deplanement.....	28	24	
Disqualification.....	156	124	
Drill, delivery unit.....	84, 158	62, 125	
Dropping:			
Rations.....	46	38	
Supplies and ammunition.....	46	38	
Duties, parachute troops:			
Company command group.....	72	57	
Company commanders.....	73	58	
Jumpmasters.....	85	63	
Platoon command group.....	64	55	
Platoon leaders.....	64, 66, 68	55, 56	
Squad leaders.....	52	50	
Employment:			
Air landing troops, principles.....	3, 4	2	
Parachute troops, principles.....	41-43, 92-118	31, 70	
Reserves.....	32	28	
Enemy, information.....	11, 12, 95, 121, 122	9, 75, 85	

TACTICS AND TECHNIQUE OF AIR-BORNE TROOPS

	Paragraph	Page
Enplaning.....	24, 55, 57, 104	20, 51 52, 77
Equipment:		
Air landing troops.....	5, 14, 15, 20, 22	3, 12, 14, 17
Parachute troops:		
Drills, training.....	134, 158	92, 125
Dropping.....	46, 54, 55	38, 51
For technical training.....	129-136	90
Jump training.....	134-143	92
Jumpmaster's inspection.....	86	65
Medical.....	79	59
Miscellaneous.....	95, 136	71, 110
Parachute packing.....	129, 130, 133	90, 91
Parachutists.....	54, 55	51
Required for technical training.....	129	90
Training building.....	131	91
Training tower.....	135	110
Rifle squad.....	50, 54	50, 51
Evacuation.....	19, 36	13, 30
Flight:		
Diagram.....	99	73
Formation.....	44, 99	34, 73
Security.....	99, 100	73, 74
Foreign languages.....	18	13
Form of orders.....	25	20
Formations of transports in flight.....	44, 99	34, 73
Guides.....	24, 26, 28	19, 22, 24
History of parachute troops.....	159	125
Hostile:		
Artillery.....	13	10
Communication.....	13, 20	10, 14
Forces.....	13	10
Information.....	11, 12, 95	9, 71
Observation.....	13	10
Positions.....	13	10
Reserves.....	13	10
Transportation.....	13, 107	10, 77
Hour of employment of parachute troops.....	94	71
Infantry, use of regularly organized.....	5	3
Information of the enemy.....	11, 12, 95, 121, 122	9, 71, 85
Initial objectives.....	3, 13, 29	2, 10, 26
Inspection:		
Equipment before jump.....	54	51
Jumpmasters.....	86	65
Personnel.....	86	65
Planes, by jumpmasters.....	86	65
Squad before enplaning.....	56	52
Issuance of orders.....	25	20
Jump training:		
Course.....	142-146, 152-157	113, 118
Disqualification.....	156	124
Outline of.....	144, 152	114, 118
Qualification standards.....	145, 152, 156	115, 118, 124

BASIC FIELD MANUAL

	Paragraph	Page
Jump training—Continued.		
Equipment.....	132, 134, 143, 153	91, 92, 113, 119
Personnel.....	143, 153	113, 119
Procedure.....	154	120
Regulations.....	155	123
Jumping platform, description.....	134	92
Jumpmaster:		
Conferences.....	97, 101, 102	72, 75, 76
Duties.....	85, 99, 154	63, 73, 120
Inspections.....	56, 57, 86	52, 65
Rehearsal.....	103	76
School.....	164	129
Jumps:		
Procedure for mass.....	58, 62	52, 55
Qualification.....	145, 152, 156	115, 118, 124
Landing areas:		
Size.....	44, 92, 93, 153	34, 70, 119
Operations to seize.....	107	77
Landing trainer, description.....	134	92
Liaison:		
After landing.....	28, 122, 123	24, 85, 86
Established prior to operations.....	20, 98, 119-122	14, 73, 85
Parachute—air landing troops.....	20, 98, 123	14, 73, 86
With other arms.....	20, 98, 119-122	14, 73, 85
Limitations of parachute operations.....	42	32
Loading:		
Air transport movement table.....	24, 26	19, 22
Loading officer.....	24, 26	19, 22
Loading plans.....	24, 26, 104	19, 22, 77
Loading tables.....	24, 26	19, 22
Parachute unit equipment.....	46, 54, 104	39, 51, 77
Maps and aerial photographs.....	12, 28, 95	9, 24, 71
Marking delivery units.....	46	38
Mass jumps, procedure.....	58	52
Medical detachments.....	19, 36, 78-80	13, 30, 59
Duties.....	19, 36, 80	13, 30, 60
Equipment.....	19, 79	13, 59
Organization.....	78	59
Supplies.....	19, 35, 79	13, 29, 59
Messengers.....	20, 34, 116	14, 28, 82
Metal trainer, description and use in training.....	134	92
Meteorological conditions.....	14, 95	12, 71
Missions:		
Air landing troops.....	3	2
As mobile reserve.....	3	2
Objectives of attacks.....	3, 30	2, 26
Parachute troops.....	41, 42, 43, 93	31, 32 33, 70
Rifle company.....	71	57
Rifle squad.....	52	50
Preliminary operations.....	9	8
Task force.....	3, 9	2, 9
Mobility.....	4	2

TACTICS AND TECHNIQUE OF AIR-BORNE TROOPS

	Paragraph	Page
Mock-up, door, description.....	134	92
Mortar squad, 60-mm:		
Armament and equipment.....	61	53
Composition.....	60	53
Motor transportation.....	5, 23, 107	3, 19, 77
Night dispositions:		
General.....	30	26
Plans and reconnaissance.....	30	26
Objectives:		
Air landing troops.....	3, 29, 30	2, 26
Of parachute operations.....	41, 42	32, 32
Officers in charge:		
Departure airport.....	24, 26	19, 22
Deplanement.....	28	24
Jumping.....	154	120
Loading.....	24, 26	19, 22
Operations:		
Air landing troops.....	27-38	24
Parachute troops.....	42, 92-118	32, 70
Orders:		
Contents.....	10, 22, 25	9, 17, 20
Discussion and instruction.....	25	20
For attacks beyond initial objective.....	30	26
Form and scope.....	25	20
From higher headquarters.....	10, 24	9, 19
Issuance.....	25	20
Rifle company.....	71	57
Organization and equipment.....	5, 15, 48-79	3, 12, 49
Organization and technique of parachute units.....	48-79	49
Organization, parachute troops.....	48-79	49
Packing:		
Building.....	130	90
Course.....	137-141	111
Delivery units.....	46, 54	38, 51
Equipment.....	130, 133, 138	90, 91, 111
Outline.....	139	111
Standards of qualification.....	140	112
Parachute.....	83, 137, 141, 162	63, 111
		112, 127
Panels.....	20, 34, 45, 116, 153	14,
		28, 35,
		82, 119
Parachute:		
Communications school.....	163	128
Demolitions school.....	161	126
Equipment.....	45	35
Group.....	88	68
Packing:		
Building.....	130	90
Course.....	137-141	111
Delivery units.....	46	38
Equipment.....	130, 133, 138	90, 91, 111

BASIC FIELD MANUAL

Parachute—Continued.	Paragraph	Page
Riggers' school.....	162	127
Specialist school.....	160-164	126
Training building.....	131	91
Training, technical.....	125-128	87
Training towers.....	132, 135, 147-151	91, 110, 115
Troops:		
Definition.....	40	31
Hour of employment.....	94	71
Missions.....	7, 42, 43, 93	4, 32 33, 70
Rehearsal.....	103	76
Selection.....	42	32
Parachutes, packing.....	46, 130	38, 90
Personnel:		
Conduct.....	38	30
Disposition.....	22, 37	17, 30
Photographs, aerial.....	12, 38, 95	9, 30, 71
Phrase sheet.....	18	13
Pigeons.....	20, 34, 116	14, 28, 82
Pilots:		
Conferences.....	97, 101	72, 75
Duties.....	99	73
Planning and preparation.....	9-28	8
Air landing troops.....	9	8
General.....	9	8
Parachute operations.....	92-107	70
Preliminary operations.....	9	8
Plans and orders:		
On arriving at destination.....	22, 23	17, 19
Prior to air departure.....	22	17
Task force.....	10-12, 93	9, 70
Plans for tactical operations:		
Preliminary studies.....	10, 21, 22, 95-97	9, 17, 71
Tentative tactical plan.....	21, 22, 92-103	17, 70
Platoon:		
81-mm mortar.....	65, 66	56
Machine gun.....	67, 68	56
Rifle.....	63, 64	55
Principles of employment:		
Air landing troops.....	3, 4	2
Parachute troops.....	41-43, 92-118	31, 70
Prisoners.....	37	30
Pyrotechnics.....	20, 34, 116	14, 28, 82
Qualification:		
 Jumping:		
Equipment and personnel.....	143, 148, 153	113, 116, 119
Procedure.....	58, 142-146, 151, 154	52, 113, 117, 120
Purpose.....	142, 147, 153	113, 115, 119
Regulations.....	146, 151, 155	115, 117, 123

TACTICS AND TECHNIQUE OF AIR-BORNE TROOPS

Qualification—Continued.	Paragraph	Page
Jumping—Continued.		
Standards.....	145, 150, 152, 156	115, 117, 118, 124
Standards:		
Jump training course.....	145, 152, 156	115, 118, 124
Jumpmaster school.....	164	129
Parachute packing course.....	140	112
Rating as parachutist.....	152	118
Tower training course.....	150	117
Radio.....	20, 34, 116	14, 28, 82
Rallying point.....	28	24
Rations:		
Air landing troops.....	16, 22, 35	12, 17, 29
Dropping.....	54, 55	51
Supply to parachute units.....	81-91	61
Reconnaissance.....	9, 11, 12, 95, 121, 122	8, 9, 71, 85
References.....	1, 39	1, 31
Regiment, parachute:		
Composition.....	77	58
Tactical employment.....	93	70
Rehearsals.....	25, 103	20, 76
Reports.....	20	14
Reserves, employment.....	32	28
Sand table, use in training.....	97	72
Schools, specialist:		
Demolitions.....	161	126
Jumpmasters.....	164	129
Parachute riggers.....	162	127
Signal communication.....	163	128
Secrecy.....	17	12
Security during flight.....	99, 100	73, 74
Signal communication:		
Command posts.....	113	81
Delivery of equipment.....	118	84
Equipment.....	115, 118	81, 84
Enemy.....	20, 117	14, 84
Means.....	20, 34, 114	14, 28, 81
Messengers.....	20, 34, 116	14, 28, 82
Missions.....	20, 110	14, 80
Officers.....	112	81
Organization.....	108, 111	80, 81
Panels.....	20, 34, 116	14, 28, 82
Pigeons.....	20, 34, 116	14, 28, 82
Pyrotechnics.....	20, 34, 116	14, 28, 82
Radio.....	20, 34, 116	14, 28, 82
Responsibility.....	20, 109	14, 80
School.....	163	128
Tactical employment.....	34, 107, 116	28, 77, 82
With supporting aviation.....	20, 34, 116	14, 28, 82
Specialist schools.....	160-164	126
Squad:		
Rifle.....	49-59	50
60-mm mortar.....	60-62	58

BASIC FIELD MANUAL

Supply:	Paragraph	Page
Ammunition.....	16, 22, 35, 54, 89	12, 17, 29, 51, 68
General.....	16, 22, 35, 76, 77, 87	12, 17, 29, 58, 68
In combat.....	22, 35, 54, 90	17, 29, 51, 69
Medical.....	16, 19, 35, 79, 80	12, 13, 29, 59, 60
Parachute units.....	87-91	68
Procedure prior to combat.....	22, 54, 89	17, 51, 68
Rations.....	16, 22, 35, 54, 55, 89	12, 17, 29, 51, 68
Responsibility.....	16, 22, 35, 77, 87	12, 17, 29, 58, 68
Rifle squad.....	54, 55	51
Water.....	16, 35, 54, 55, 89	12, 29, 51, 68
Supporting aviation:		
Communication with.....	20, 34, 108-116, 122	14, 28, 80, 85
General.....	7, 8, 119	4, 85
Limitations.....	8	4
Methods of control.....	8	4
Targets.....	8	4
Training requirements.....	8	4
Transports.....	47, 120	48, 85
Surprise, characteristic of parachute operations.....	42	32
Suspended harness, description.....	134	92
Tactical employment of parachute units.....	92-118	70
Tactical operations.....	27-38	24
Difficulties.....	27	24
Employment of parachute units.....	27	24
General.....	27	24
Guides.....	24, 26, 28	19, 22, 24
Upon landing.....	28	24
Parachute troops.....	92-118	70
Plans.....	25	20
Targets.....	8	4
Task force:		
Commander.....	2, 9, 10, 17, 10, 20, 21, 93	1, 8, 9, 12, 13, 14, 17, 70
Definition.....	2	1
Telephones.....	20, 34	14, 28
Terrain, influence on parachute operations.....	44	34
Time:		
Limitations on parachute operations.....	42, 92	32, 70
Of attack.....	94	71
Of employment, parachute troops.....	94	71

TACTICS AND TECHNIQUE OF AIR-BORNE TROOPS

	Paragraph	Page
Tower, training-----	147-151	115
Equipment-----	134, 148	92, 116
Outline of course-----	149	116
Purpose-----	147	115
Qualification standards-----	150	117
Training:		
Buildings-----	131, 134	91, 92
Commanders and staffs-----	6	3
Communication-----	20	1*
Demolitions school-----	161	126
In combined air-ground operations-----	20, 25	14, 20
Jump course-----	142-146, 152-157	113, 118
Jumpmaster school-----	164	129
Packing-----	137-141	111
Phases-----	81	61
Parachute riggers' school-----	162	127
Preliminary-----	25	20
Rehearsals-----	25	20
Requirements-----	25	20
Specialist schools-----	160-164	126
Technical parachute-----	125-128	87
Conduct of-----	127	88
Purpose-----	125	87
Scope-----	126	88
Time required-----	128	89
Towers-----	132, 135, 147-151	91, 110, 115
Troops-----	6, 25	3, 20
Unit-----	82-84	61
With combat aviation-----	20, 25, 103	14, 20, 76
Trampoline trainer-----	134	92
Transport aviation:		
Characteristics-----	47	47
Formations in flight-----	44, 99	34, 73
Transportation:		
Seizure of enemy-----	107	77
Type:		
Delivery units-----	46	38
Parachute operations-----	43	33
Water-----	16, 35, 55, 89	12, 29, 51, 68
Windcharger, description and use-----	134	92
Vulnerability-----	4	2

